

CONTACTORS MOTOR STARTERS INDUSTRIAL RELAYS



FUJI ELECTRIC

Fuji Electric Co., Ltd. has met the changing needs of society since being founded in 1923. The Company's technological strengths allow it to fulfill its responsibilities as a corporate and social leader ahead of its time. Over the years, Fuji Electric has entered many business fields, from the production of electronic devices and various components to large-scale systems such as electric power plants. Fuji Electric has 80+ years of experience in developing total systems and solutions for our customers.

With businesses ranging across many fields and as its mission expands, Fuji Electric is becoming increasingly aware of its role in the global society. The Company is redoubling its efforts to develop new technologies that will make an ever larger social contribution.

Fuji Electric is a global company with sales, service and manufacturing facilities located worldwide.

DISTRIBUTION AND CONTROL DEPARTMENT

Fuji Electric's Distribution and Control (D&C) Department offers products in the electric distribution and control system fields. Major products include control equipment, such as magnetic motor contactors and push-button switches as well as electrical distribution equipment, such as molded-case circuit breakers and earth-leakage circuit breakers.

Fuji Electric's D&C Department's UL Listed and CSA Certified products provide control design / application engineers and users with an economically sound alternative choice without compromising quality, reliability or durability for years of service. D & C products are used in machine tools, motor control centers, distribution boards, industrial machines, control panels, and instrumentation panels, as well as a host of other applications.

The Distribution and Control Department has a network of distributors and representatives throughout the United States that provide first-rate service and response.

HIGH PERFORMANCE CONTACTORS AND STARTERS

Engineered for cost and application advantages

Contactors and Starters provide the best of both worlds..... Quality and Economy

Designed to globally accepted approvals and ratings

- Engineered for quality performance, day after day
- Wide variety of frame sizes - up to 700HP
- Overload relays feature open phase protection
- Contactors through 10HP at 480V offer industry's longest life expectancy - 2 million electrical operations

Table of Contents

	Page
"ORANGE LINE" Quick Selection Guide	5
"ODYSSEY SERIES" Quick Selection Guide.....	6
"ORANGE LINE" Contactors, AC Operated	8
"ORANGE LINE" Contactors, DC Operated	10
"ORANGE LINE" Motor Starters, AC Operated	12
"ORANGE LINE" Motor Starters, DC Operated	14
"ORANGE LINE" Thermal Overload Relays	16
"ORANGE LINE" Accessories	18
"ORANGE LINE" Dimensions	20
"ODYSSEY SERIES" Contactors & Starters, AC Operated	23
"ODYSSEY SERIES" Contactors & Starters, DC Operated	25
"ODYSSEY SERIES" Contactors, AC or DC Operated	27
"ODYSSEY SERIES" Motor Starters, AC or DC Operated	29
"ODYSSEY SERIES" Thermal Overload Relays	31
"ODYSSEY SERIES" Accessories	33
"ODYSSEY SERIES" Replacement Parts	36
"ODYSSEY SERIES" Dimensions	37
Technical Performance Data	49
"ORANGE LINE" Industrial Relay	54
"SK SERIES" Mini Contactors, Quick Selection Guide	58
"SK SERIES" Mini Contactors, Type Number Nomenclature	60
"SK SERIES" Mini Contactors, Dimensions	61
"SK SERIES" Thermal Overload Relays	62
"SK SERIES" Accessories	63
"SK SERIES" Auxiliary Relays	64
SF SERIES	67
Cross chart from old contactor to latest contactor.....	70
Terms & Conditions	73

"ORANGE" LINE
UP TO 10HP@ 480VAC

- 2 million electrical operations. The longest in the industry.
- "Logic level" aux contacts allow consistent operation down to 5VDC 3mA.
- Overloads offer "Open phase protection" as a standard feature.

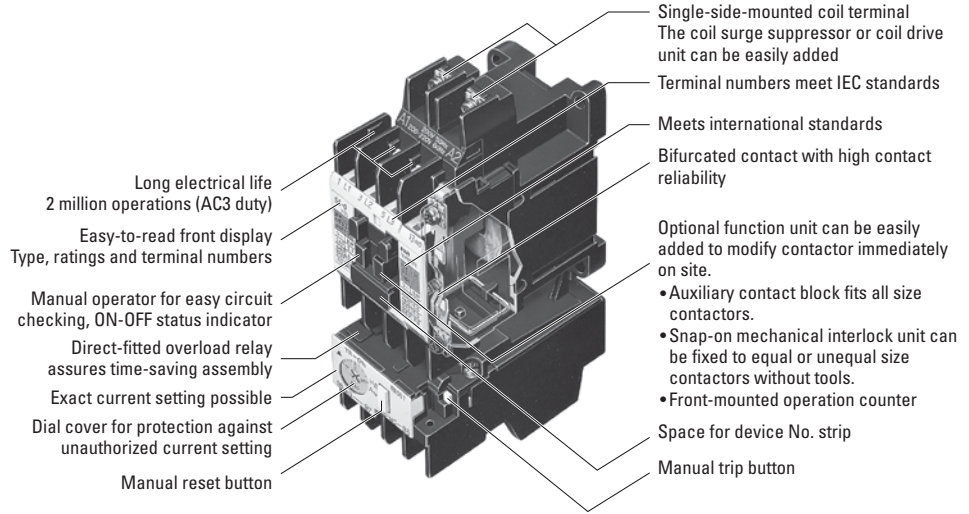

Easy coil replacement without screws

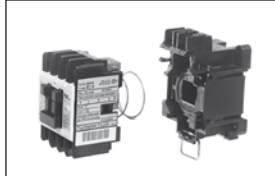

Snap-on 35mm IEC and DIN rail mounting
 Flat side construction allows side-by-side mounting

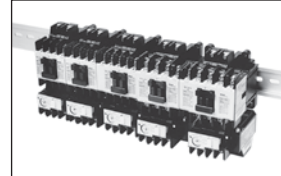

See pages 8 through 19 for details

ODYSSEY SERIES
(Conventional Coils)
UP TO 50HP@ 480VAC

- Redesigned coil offers lower power consumption characteristics.
- Compact size allows for efficient panel layout.
- 2N0+2NC aux contacts are included.

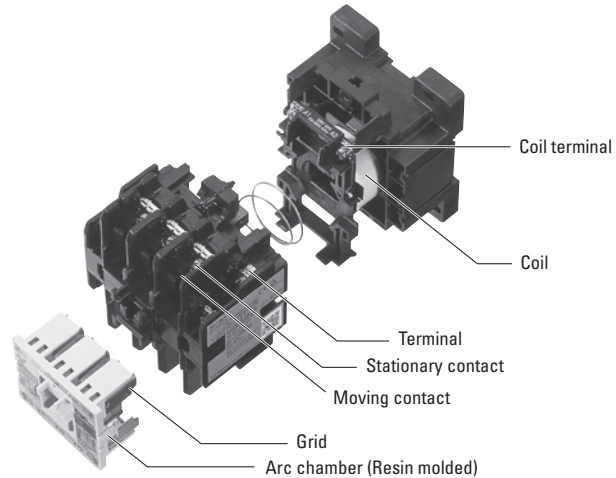

See pages 23 through 26 for details

ODYSSEY SERIES
(Featuring Super Magnet Technology)
UP TO 600HP@ 480VAC

- Coil operates on either AC or DC voltage.
- Chatter-free operation, eliminates contact welding & coil burning.
- "Super magnet" design offers advanced electronics for maximum dependability.

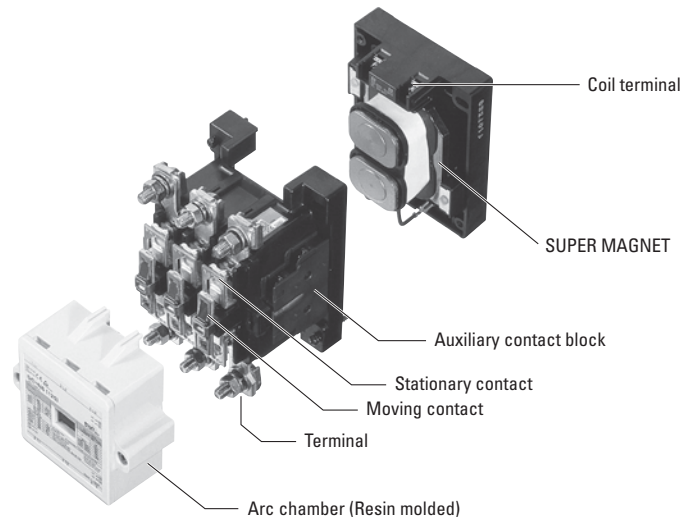

See pages 27 through 30 for details

SUPER MAGNET THEORY & EXPLANATION

ADVANTAGES OF SUPER MAGNET

■ POSITIVE PICK-UP AND DROP-OUT

The SUPER MAGNET operation is electronically controlled. There is no unstable zone as will be seen in the diagram, an outstanding feature that other contactors cannot provide. Chattering is a phenomenon which occurs when the gravitational force of the starter magnet, decreases through the line voltage drop at the time of motor starting. This may cause damage such as contact welding or coil burning. The SUPER MAGNET holds without chattering even if the line voltage drops to 65% of its rated value, thereby preventing this type of trouble.

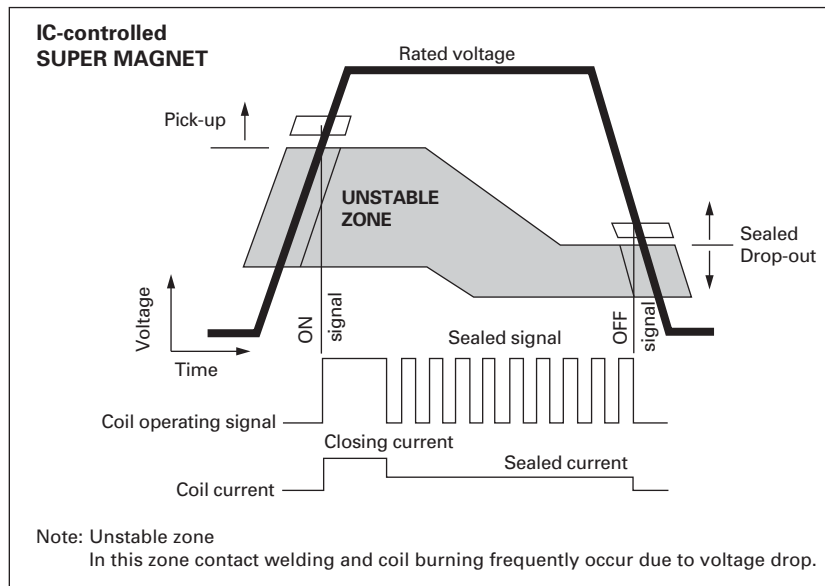

Motor starting

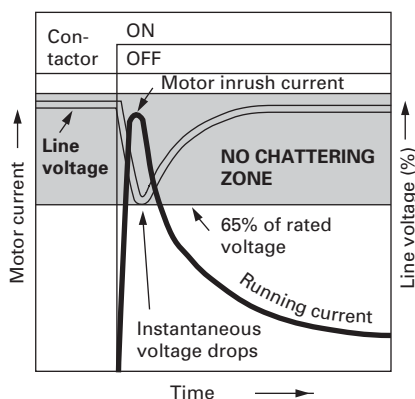

Note: No chattering occurs even if instantaneous voltage drops to 65% of rated voltage.

Conventional contactors

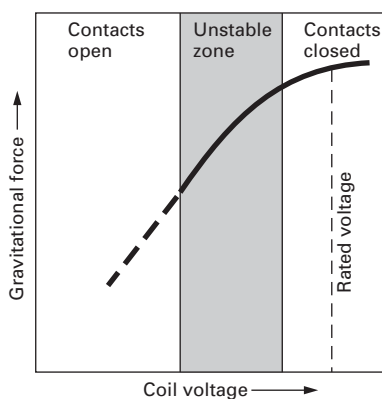

Contactors featuring Super Magnet technology

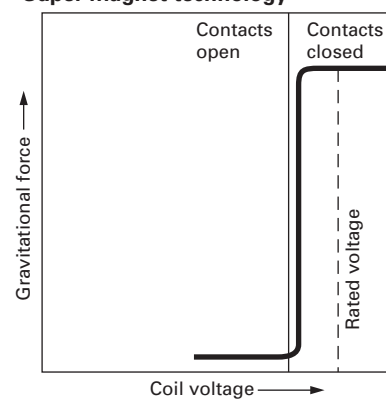

Note: Since SC series contactors are electronically controlled there is no unstable zone.

■ OPERATION ON BOTH AC AND DC INPUTS

The rated operational voltage range of the Super Magnet series contactors has been greatly expanded. They operate on both AC (50/60Hz) and DC inputs.

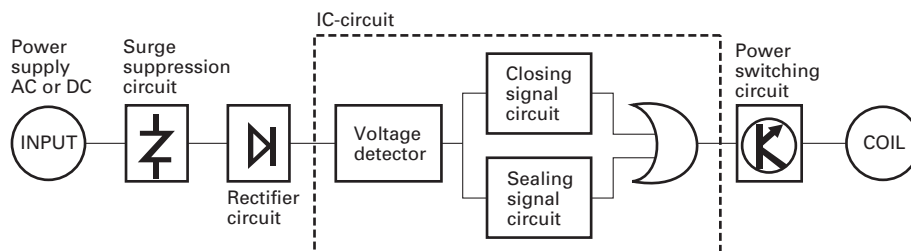

Coils (3F to 5H)

Rated voltage	Rated coil voltage, frequency		
	AC		DC
24V	24-25V	50/60Hz	24V
48V	48-50V	50/60Hz	48V
100V	100-127V	50/60Hz	100-110V
200V	200-250V	50/60Hz	200-240V
300V	265-347V	50/60Hz	-
400V	380-450V	50/60Hz	-
500V	460-575V	50/60Hz	-

Operation

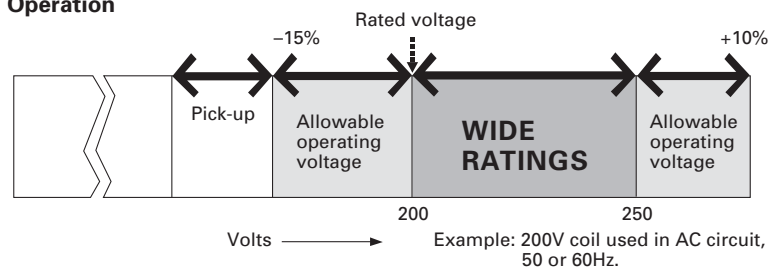

"ORANGE LINE" Quick Selection Guide

U.S. Standard Models

Series			Orange Line						Further Information
Frame			0A	0F	0G	0Q	0R	0H	
Contactor Appearance									
Fuji Type			SC-03	SC-0	SC-05	SC-4-0	SC-4-1	SC-5-1	
Standard	Non-reversing	Contactor	4NC0A0	4NC0F0	4NC0G0	4NC0Q0	4NC0R0	4NC0H0	page 8
		Starter	4NW0A0	4NW0F0	4NW0G0	4NW0Q0	4NW0R0	4NW0H0	page 12
	Reversing	Contactor	4ND0A0	4ND0F0	4ND0G0	4ND0Q0	4ND0R0	4ND0H0	page 8
		Starter	4NX0A0	4NX0F0	4NX0G0	4NX0Q0	4NX0R0	4NX0H0	page 12
DC-operated	Non-reversing	Contactor	4GC0A0	4GC0F0	4GC0G0	4GC0Q0	4GC0R0	4GC0H0	page 10
		Starter	4GW0A0	4GW0F0	4GW0G0	4GW0Q0	4GW0R0	4GW0H0	page 14
	Reversing	Contactor	4GD0A0	4GD0F0	4GD0G0	4GD0Q0	4GD0R0	4GD0H0	page 10
		Starter	4GX0A0	4GX0F0	4GX0G0	4GX0Q0	4GX0R0	4GX0H0	page 14
Thermal Overload Relay			4NK0A	4NK0A	4NK0A	4NK0H	4NK0H	4NK0H	page 16
3Phase HP Rating [HP] (AC-3)	200-208V		2	3	3	5	5	5	
	220-240V		2	3	3	5	5	5	
	400-480V		5	5	5	7.5	10	10	
	550-600V		5	5	5	7.5	10	10	
Full Load Ampere Rating [A] (AC-3)	200-208V		7.8	11	11	17.5	17.5	17.5	
	220-240V		6.8	9.6	9.6	15.2	15.2	15.2	
	400-480V		7.6	7.6	7.6	11	14	14	
	550-600V		6.1	6.1	6.1	9	11	11	
Auxiliary Contact Arrangement			1NO 1NC		1NO+1NC 2NO, 2NC	1NO 1NC		1NO+1NC 2NO, 2NC	
Rated Thermal Current [A] (AC-1)			11	13	13	20	20	20	
Performances	Operating cycles per hour		1800	1800	1800	1800	1800	1800	
	Durability (x 10,000)	Mechanical	1000	1000	1000	1000	1000	1000	
		Electrical	200	200	200	150	200	200	
Dimensions (mm)	H		80		80	80		80	
	W		43		53	53		64	
	D		80		80	81		81	
Accessories	Auxiliary Contact Blocks	Front Mounting	⊙	⊙	⊙	⊙	⊙	⊙	page 19
		Side Mounting	⊙	⊙	⊙	⊙	⊙	⊙	page 19
	Coil Surge Suppression Unit		⊙	⊙	⊙	⊙	⊙	⊙	page 19
	Main Circuit Suppression Unit		⊙	⊙	⊙	⊙	⊙	⊙	page 19
	Terminal Cover		⊙	⊙	⊙	⊙	⊙	⊙	page 19
	Replacement Contacts		⊙	⊙	⊙	⊙	⊙	⊙	page 19
Standards			UL 508 (UL File No: E42419), CSA 22.2, IEC 60947-1, EN 60947-4-1, VDE 0660, JIS C 8201-4-1						

⊙ : Available

"ODYSSEY SERIES" Quick Selection Guide

U.S. Standard Models

Series			Odyssey Series					Further Information
Frame			0T	1Q	2F	2H	2T	
Contactor Appearance								
Fuji Type			SC-N1	SC-N2	SC-N2S	SC-N3	SC-N4	
Standard	Non-reversing	Contactor	3NC0T0	3NC1Q0	3NC2F0	3NC2H0	3NC2T0	page 23
		Starter	3NW0T0	3NW1Q0	3NW2F0	3NW2H0	3NW2T0	
	Reversing	Contactor	3ND0T0	3ND1Q0	3ND2F0	3ND2H0	3ND2T0	
		Starter	3NX0T0	3NX1Q0	3NX2F0	3NX2H0	3NX2T0	
DC-operated	Non-reversing	Contactor	3GC0T0	3GC1Q0	3GC2F0	3GC2H0	3GC2T0	
		Starter	3GW0T0	3GW1Q0	3GW2F0	3GW2H0	3GW2T0	
	Reversing	Contactor	3GD0T0	3GD1Q0	3GD2F0	3GD2H0	3GD2T0	
		Starter	3GX0T0	3GX1Q0	3GX2F0	3GX2H0	3GX2T0	
Supermagnet Type ¹	Non-reversing	Contactor	3NC0T0.../SE	3NC1Q0.../SE	3NC2F0.../SE	3NC2H0.../SE	3NC2T0.../SE	page 27
		Starter	3NW0T0.../SE	3NW1Q0.../SE	3NW2F0.../SE	3NW2H0.../SE	3NW2T0.../SE	page 29
	Reversing	Contactor	3ND0T0.../SE	3ND1Q0.../SE	3ND2F0.../SE	3ND2H0.../SE	3ND2T0.../SE	page 27
		Starter	3NX0T0.../SE	3NX1Q0.../SE	3NX2F0.../SE	3NX2H0.../SE	3NX2T0.../SE	page 29
Thermal Overload Relay			3NK1Q	3NK1Q	3NK2H	3NK2H	3NK3F	page 32
3Phase HP Rating [HP] (AC-3)	200-208V		7.5	10	15	20	25	
	220-240V		10	15	20	25	30	
	400-480V		25	30	40	50	60	
	550-600V		25	30	40	50	60	
Full Load Ampere Rating [A] (AC-3)	200-208V		25.3	32.2	48.3	62.1	78.2	
	220-240V		28	42	54	68	80	
	400-480V		34	40	52	65	77	
	550-600V		27	32	41	52	62	
Rated Thermal Current [A] (AC-1)			50	60	80	100	135	
Auxiliary Contact Arrangement			2NO+2NC					
Performances	Operating cycles per hour		1200	1200	1200	1200	1200	
	Durability (x 10,000)	Mechanical	1000	1000	500	500	500	
		Electrical	200	200	200	200	100	
Dimensions (mm)	H		87	87	110	110	127	
	W		74	74	88	88	88	
	D		96	96	111	111	117	
Accessories	Auxiliary Contact Blocks	Front Mounting	⊙	⊙	⊙	⊙	⊙	page 34-35 ²
		Side Mounting	⊙	⊙	⊙	⊙	⊙	page 34-35 ²
	Coil Surge Suppression Unit		⊙	⊙	⊙	⊙	⊙	page 34-35 ²
	Main Circuit Suppression Unit		⊙	⊙	⊙	⊙	⊙	page 34-35 ²
	Terminal Cover		⊙	⊙	⊙	⊙	⊙	page 34-35 ²
	Replacement Contacts		⊙	⊙	⊙	⊙	⊙	page 34-35 ²
Standards			UL 508 (UL File No: E42419), CSA 22.2, IEC 60947-1, EN 60947-4-1, VDE 0660, JIS C 8201-4-1					



¹ = Supermagnet type come built in with surge suppression circuitry

² = Page 33 Accessory for 2T frame size

⊙ : Available

"ODYSSEY SERIES" Quick Selection Guide

U.S. Standard Models

Series			Odyssey Series								Further Information	
Frame			3F	3H	4F	4Q	4H	5F	5H	6F		6H
Contactor Appearance											Further Information	
Fuji Type			SC-N5	SC-N6	SC-N7	SC-N8	SC-N10	SC-N11	SC-N12	SC-N14		SC-N16
Supermagnet Type	Non-reversing	Contactor	3NC3F0	3NC3H0	3NC4F0	3NC4Q0	3NC4H0	3NC5F0	3NC5H0	3NC6F0	3NC6H0	page 27
		Starter	3NW3F0	3NW3H0	3NW4F0	3NW4Q0	3NW4H0	3NW5F0	3NW5H0	-	-	page 29
	Reversing	Contactor	3ND3F0	3ND3H0	3ND4F0	3ND4Q0	3ND4H0	3ND5F0	3ND5H0	3ND6F0	3ND6H0	page 27
		Starter	3NX3F0	3NX3H0	3NX4F0	3NX4Q0	3NX4H0	3NX5F0	3NX5H0	-	-	page 29
Thermal Overload Relay			3NK3F	3NK3H	3NK4F	3NK4Q	3NK4H	3NK5H	3NK5H	-	-	page 32
3Phase HP Rating [HP] (AC-3)	200-208V		30	40	50	60	75	100	125	200	250	
	220-240V		30	40	50	60	75	100	150	200	300	
	400-480V		60	75	100	150	150	200	300	500	600	
UL508	550-600V		75	100	125	150	200	250	350	600	700	
Full Load Ampere Rating [A] (AC-3)	200-208V		92	119.6	149.5	177.1	220.8	285.2	358.6	552	692.3	
	220-240V		80	104	130	154	192	248	360	480	720	
	400-480V		77	96	124	180	180	240	361	590	722	
	550-600V		77	99	125	144	192	242	336	578	672	
Rated Thermal Current [A] - (AC1)			150	150	200	260	260	350	450	660	800	
Auxiliary Contact Arrangement			2NO+2NC									
Performances	Operating cycles per hour		1200	1200	1200	1200	1200	1200	1200	1200	1200	
	Durability (x 10,000)	Mechanical	500	500	500	500	500	500	500	500	200	
		Electrical	100	100	100	100	100	100	100	50	50	25
Dimensions (mm)	H		127	144	156	209	209	240	240	332	332	
	W		88	100	115	138	138	148	148	290	290	
	D		132	138	140	174	174	195	195	328	328	
Accessories	Auxiliary Contact Blocks	Front Mounting	-	-	-	-	-	-	-	-	-	page 35
		Side Mounting	⊙	⊙	⊙	⊙	⊙	⊙	⊙	⊙	⊙	page 35
	Coil Surge Suppression Unit		_*1	_*1	_*1	_*1	_*1	_*1	_*1	_*1	_*1	page 35
	Main Circuit Suppression Unit		-	-	-	-	-	-	-	-	-	page 35
	Terminal Cover		⊙	⊙	⊙	⊙	⊙	⊙	⊙	⊙	⊙	page 35
	Replacement Contacts		⊙	⊙	⊙	⊙	⊙	⊙	⊙	⊙	⊙	page 35
Standards			UL 508 (UL File No: E42419), CSA 22.2, IEC 60947-1, EN 60947-4-1, VDE 0660, JIS C 8201-4-1									

*1 = Supermagnet type come built in with surge suppression circuitry

⊙ : Available

- : Not Available

"ORANGE LINE" AC Contactors, AC Operated



■ NON-REVERSING CONTACTORS UL File No. E42419, E44592 cUL listed

1 Phase HP Rating (Full load ampere)		3 Phase HP Ratings (Full load ampere)				Rated thermal current for non inductive / resistive load	Qty. of Auxiliary Contacts	Part Number	Fuji Type	Frame Size
100-120V	220-240V	200-208V	220-240V	440-480V	550-600V					
1/3 (7.2)	1 (8)	2 (7.8)	2 (6.8)	5 (7.6)	5 (6.1)	11	1	4NC0A0#@@%	SC-03	0A
1/3 (7.2)	1 (8)	3 (11)	3 (9.6)	5 (7.6)	5 (6.1)	13	1	4NC0F0#@@%	SC-0	0F
1/3 (7.2)	1 (8)	3 (11)	3 (9.6)	5 (7.6)	5 (6.1)	13	2	4NC0G0#@@%	SC-05	0G
1 (16)	2 (12)	5 (17.5)	5 (15.2)	7 1/2 (11)	7 1/2 (9)	20	1	4NC0Q0#@@%	SC-4-0	0Q
1 (16)	2 (12)	5 (17.5)	5 (15.2)	10 (14)	10 (11)	20	1	4NC0R0#@@%	SC-4-1	0R
1 (16)	2 (12)	5 (17.5)	5 (15.2)	10 (14)	10 (11)	20	2	4NC0H0#@@%	SC-5-1	0H

■ REVERSING CONTACTORS UL File No. E42419, E44592 cUL listed

1 Phase HP Rating (Full load ampere)		3 Phase HP Ratings (Full load ampere)				Rated thermal current for non inductive / resistive load	Qty. of Auxiliary Contacts	Part Number	Fuji Type	Frame Size
100-120V	220-240V	200-208V	220-240V	440-480V	550-600V					
1/3 (7.2)	1 (8)	2 (7.8)	2 (6.8)	5 (7.6)	5 (6.1)	11	1	4ND0A0#@@%	SC-03RM	0A
1/3 (7.2)	1 (8)	3 (11)	3 (9.6)	5 (7.6)	5 (6.1)	13	1	4ND0F0#@@%	SC-0RM	0F
1/3 (7.2)	1 (8)	3 (11)	3 (9.6)	5 (7.6)	5 (6.1)	13	2	4ND0G0#@@%	SC-05RM	0G
1 (16)	2 (12)	5 (17.5)	5 (15.2)	7 1/2 (11)	7 1/2 (9)	20	1	4ND0Q0#@@%	SC-4-0RM	0Q
1 (16)	2 (12)	5 (17.5)	5 (15.2)	10 (14)	10 (11)	20	1	4ND0R0#@@%	SC-4-1RM	0R
1 (16)	2 (12)	5 (17.5)	5 (15.2)	10 (14)	10 (11)	20	2	4ND0H0#@@%	SC-5-1RM	0H

Note: The list above indicates the No. of auxiliary contacts provided per contactor.

If larger contactors are required, please turn to page 23.

EXPLANATION OF PART NUMBER SYSTEM

4 N C 0 A 0 # @ @ %

• **PRODUCT LINE**
4= Orange Line

• **OPERATION**
N=AC Coil
G=DC Coil

• **DESCRIPTION**
C=Non-Reversing Contactor
D=Reversing Contactor

• **FRAME SIZE**

• **TERMINAL OPTION**

Blank: Standard
Y: Optional, non-removable terminal cover accessory.
(Note: Y type not available for 0Q or 0R frame sizes)

• **QUANTITY OF AUX. CONTACTS**

10 : 1NO 20 : 2NO
01 : 1NC 02 : 2NC
11 : 1NO+1NC

See above under the "Qty. of Aux Contacts" column or next page.

• **COIL VOLTAGE**

Select code from chart on next page

• **FRAME ENCLOSURE**

0=Open Frame, No Enclosure

"ORANGE LINE" AC Contactors, AC Operated

AVAILABLE COILS

Code Letter	AC Coil 60Hz	AC Coil 50Hz
E	24-26V	24V
F	48-52V	48V
A	100-110V	100V
1	110-120V	100-110V
G	120-130V	110-120V
B	200-220V	200V
2	220-240V	200-220V
C	400-440V	380-400V
4	440-480V	415-440V
5	550-600V	500-550V

If DC operation is required, please turn to page 10-11.

COIL CHARACTERISTICS

Frame Size	Power Consumption (VA)		Pick-up Voltage (V)	Drop-out Voltage (V)	Operating Time (ms)	
					Coil ON	Coil OFF
Inrush Sealed					Contact ON	Contact OFF
0A	95	9	58-68	40-55	9-20	5-16
0F	95	9	58-68	40-55	9-20	5-16
0G	95	9	58-68	40-55	9-20	5-16
0Q	95	9	65-73	44-60	9-20	5-16
0R	95	9	65-73	44-60	9-20	5-16
0H	95	9	65-73	44-60	9-20	5-16

This data is based on 110-120VAC, 50/60Hz coil, tested at 120VAC, 60Hz. For additional coil data, please see page 51.

WIRING DIAGRAMS / AUXILIARY CONTACT INFORMATION

NON-REVERSING CONTACTORS

(4NC0A0, 0F0, 0Q0 and 0R0)

1NO* (Standard)*

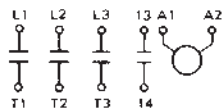

(4NC0G0 and 4NC0H0)

1NO+1NC (Standard)**

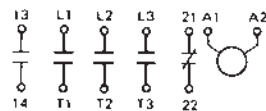

1NC* (Option)

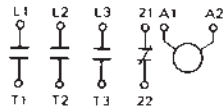

2NO** (Option)

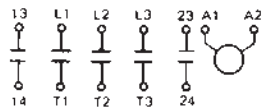

2NC** (Option)

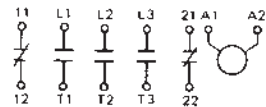

REVERSING CONTACTORS

(4ND0A0, 0F0, 0Q0, 0R0)

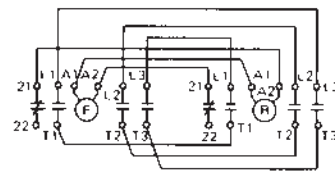

(4ND0G0 and 4ND0H0)

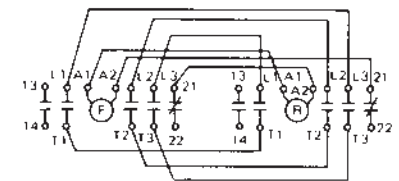

AUXILIARY CONTACT RATINGS

Operating	Contact rating Code Designation	Continuous Ampere Rating	Current-Make/Break (A)			
			110 to 120V	220 to 240V	440 to 480V	550 to 600V
AC	A600	10	60/6	30/3	15/1.5	12/1.2
DC	Q300	10	120V	240V		
			0.55/0.55	0.27/0.27		

* The 0A, 0F, 0Q & 0R frames offer 1 Aux. contact, NO standard. However, NC is available as an option.

** The 0G & 0H frames offer 2 Aux. contacts, 1NO + 1NC standard. However, 2NO or 2NC is available as an option.

"ORANGE LINE" AC Contactors, DC Operated



■ NON-REVERSING CONTACTORS UL File No. E42419, E44592 cUL listed

1 Phase HP Rating (Full load ampere)		3 Phase HP Ratings (Full load ampere)				Rated thermal current for non inductive / resistive load	Qty. of Auxiliary Contacts	Part Number	Fuji Type	Frame Size
100-120V	220-240V	200-208V	220-240V	440-480V	550-600V					
1/3 (7.2)	1 (8)	2 (7.8)	2 (6.8)	5 (7.6)	5 (6.1)	11	1	4GC0A0#@@%	SC-03/G	0A
1/3 (7.2)	1 (8)	3 (11)	3 (9.6)	5 (7.6)	5 (6.1)	13	1	4GC0F0#@@%	SC-0/G	0F
1/3 (7.2)	1 (8)	3 (11)	3 (9.6)	5 (7.6)	5 (6.1)	13	2	4GC0G0#@@%	SC-05/G	0G
1 (16)	2 (12)	5 (17.5)	5 (15.2)	7 1/2 (11)	7 1/2 (9)	20	1	4GC0Q0#@@%	SC-4-0/G	0Q
1 (16)	2 (12)	5 (17.5)	5 (15.2)	10 (14)	10 (11)	20	1	4GC0R0#@@%	SC-4-1/G	0R
1 (16)	2 (12)	5 (17.5)	5 (15.2)	10 (14)	10 (11)	20	2	4GC0H0#@@%	SC-5-1/G	0H

■ REVERSING CONTACTORS UL File No. E42419, E44592 cUL listed

1 Phase HP Rating (Full load ampere)		3 Phase HP Ratings (Full load ampere)				Rated thermal current for non inductive / resistive load	Qty. of Auxiliary Contacts	Part Number	Fuji Type	Frame Size
100-120V	220-240V	200-208V	220-240V	440-480V	550-600V					
1/3 (7.2)	1 (8)	2 (7.8)	2 (6.8)	5 (7.6)	5 (6.1)	11	1	4GD0A0#@@%	SC-03RM/G	0A
1/3 (7.2)	1 (8)	3 (11)	3 (9.6)	5 (7.6)	5 (6.1)	13	1	4GD0F0#@@%	SC-0RM/G	0F
1/3 (7.2)	1 (8)	3 (11)	3 (9.6)	5 (7.6)	5 (6.1)	13	2	4GD0G0#@@%	SC-05RM/G	0G
1 (16)	2 (12)	5 (17.5)	5 (15.2)	7 1/2 (11)	7 1/2 (9)	20	1	4GD0Q0#@@%	SC-4-0RM/G	0Q
1 (16)	2 (12)	5 (17.5)	5 (15.2)	10 (14)	10 (11)	20	1	4GD0R0#@@%	SC-4-1RM/G	0R
1 (16)	2 (12)	5 (17.5)	5 (15.2)	10 (14)	10 (11)	20	2	4GD0H0#@@%	SC-5-1RM/G	0H

Note: The list above indicates the No. of auxiliary contacts provided per contactor.

If larger contactors are required, please turn to page 25.

EXPLANATION OF PART NUMBER SYSTEM

4 G C 0 A 0 # @ @ %

• **PRODUCT LINE**
4= Orange Line

• **OPERATION**
N=AC Coil
G=DC Coil

• **DESCRIPTION**
C=Non-Reversing Contactor
D=Reversing Contactor

• **FRAME SIZE**

• **TERMINAL OPTION**

Blank: Standard
Y: Optional, non-removable terminal cover accessory.
(Note: Y type not available for 0Q or 0R frame sizes)

• **QUANTITY OF AUX. CONTACTS**

10 : 1NO 20 : 2NO
01 : 1NC 02 : 2NC
11 : 1NO+1NC

See above under the "Qty. of Aux Contacts" column or next page.

• **COIL VOLTAGE**

Select code from chart on next page

• **FRAME ENCLOSURE**

0=Open Frame, No Enclosure

"ORANGE LINE" AC Contactors, DC Operated

AVAILABLE COILS

Code Letter	DC Coil
T	12V
M	24V
N	48V
1	100V
R	110V
2	200V
S	220V

If AC operation is required, please turn to page 8-9.

COIL CHARACTERISTICS

Frame Size	Power Consumption (VA)		Pick-up Voltage (V)	Drop-out Voltage (V)	Operating Time (ms)	
	Inrush Sealed				Coil ON ↓ Contact ON	Coil OFF ↓ Contact OFF
0A	7	7	11-15	3-6	43-47	22-24
0F	7	7	11-15	3-6	43-47	22-24
0G	7	7	10-15	3-7	43-47	22-24
0Q	7	7	11-15	3-7	44-48	22-25
0R	7	7	11-15	3-7	44-48	22-25
0H	7	7	11-16	4-7	45-49	22-26

This data is based on 24-26VDC coil, tested at 24VDC. For additional coil data, please see page 52.

WIRING DIAGRAMS / AUXILIARY CONTACT INFORMATION

NON-REVERSING CONTACTORS

(4GC0A0, 0F0, 0Q0 and 0R0)

1NO* (Standard)*

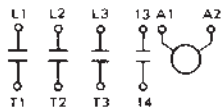

(4GC0G0 and 4GC0H0)

1NO+1NC (Standard)**

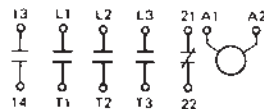

1NC* (Option)

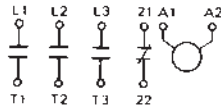

2NO** (Option)



2NC** (Option)

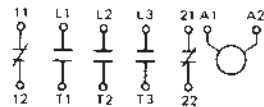

REVERSING CONTACTORS

(4GD0A0, 0F0, 0Q0, 0R0)

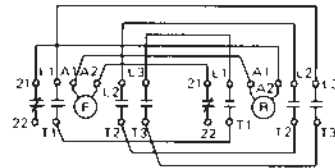

(4GD0G0 and 4GD0H0)

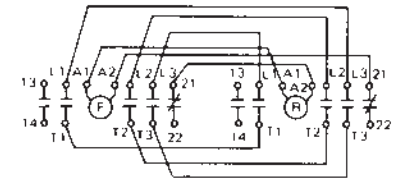

AUXILIARY CONTACT RATINGS

Operating	Contact Rating Code Designation	Continuous Ampere Rating	Current-Make/Break (A)			
			110 to 120V	220 to 240V	440 to 480V	550 to 600V
AC	A600	10	60/6	30/3	15/1.5	12/1.2
DC	Q300	10	120V	240V	0.55/0.55	0.27/0.27

* The 0A, 0F, 0Q & 0R frames offer 1 Aux. contact, NO standard. However, NC is available as an option.

** The 0G & 0H frames offer 2 Aux. contacts, 1NO + 1NC standard. However, 2NO or 2NC is available as an option.

"ORANGE LINE" AC Motor Starters, AC Operated



■ NON-REVERSING MOTOR STARTERS UL File No. E42419, E44592 cUL listed

1 Phase HP Rating (Full load ampere)		3 Phase HP Ratings (Full load ampere)				Rated thermal current for non inductive / resistive load	Qty. of Auxiliary Contacts	Part Number	Fuji Type	Frame Size
100-120V	220-240V	200-208V	220-240V	440-480V	550-600V					
1/3 (7.2)	1 (8)	2 (7.8)	2 (6.8)	5 (7.6)	5 (6.1)	11	1	4NW0A0#*@@K%	SW-03/2E	0A
1/3 (7.2)	1 (8)	3 (11)	3 (9.6)	5 (7.6)	5 (6.1)	13	1	4NW0F0#*@@K%	SW-0/2E	0F
1/3 (7.2)	1 (8)	3 (11)	3 (9.6)	5 (7.6)	5 (6.1)	13	2	4NW0G0#*@@K%	SW-05/2E	0G
1 (16)	2 (12)	5 (17.5)	5 (15.2)	7 1/2 (11)	7 1/2 (9)	20	1	4NW0Q0#*@@K%	SW-4-0/2E	0Q
1 (16)	2 (12)	5 (17.5)	5 (15.2)	10 (14)	10 (11)	20	1	4NW0R0#*@@K%	SW-4-1/2E	0R
1 (16)	2 (12)	5 (17.5)	5 (15.2)	10 (14)	10 (11)	20	2	4NW0H0#*@@K%	SW-5-1/2E	0H

■ REVERSING MOTOR STARTERS UL File No. E42419, E44592 cUL listed

1 Phase HP Rating (Full load ampere)		3 Phase HP Ratings (Full load ampere)				Rated thermal current for non inductive / resistive load	Qty. of Auxiliary Contacts	Part Number	Fuji Type	Frame Size
100-120V	220-240V	200-208V	220-240V	440-480V	550-600V					
1/3 (7.2)	1 (8)	2 (7.8)	2 (6.8)	5 (7.6)	5 (6.1)	11	1	4NX0A0#*@@K%	SW-03RM/2E	0A
1/3 (7.2)	1 (8)	3 (11)	3 (9.6)	5 (7.6)	5 (6.1)	13	1	4NX0F0#*@@K%	SW-0RM/2E	0F
1/3 (7.2)	1 (8)	3 (11)	3 (9.6)	5 (7.6)	5 (6.1)	13	2	4NX0G0#*@@K%	SW-05RM/2E	0G
1 (16)	2 (12)	5 (17.5)	5 (15.2)	7 1/2 (11)	7 1/2 (9)	20	1	4NX0Q0#*@@K%	SW-4-0RM/2E	0Q
1 (16)	2 (12)	5 (17.5)	5 (15.2)	10 (14)	10 (11)	20	1	4NX0R0#*@@K%	SW-4-1RM/2E	0R
1 (16)	2 (12)	5 (17.5)	5 (15.2)	10 (14)	10 (11)	20	2	4NX0H0#*@@K%	SW-5-1RM/2E	0H

Note: The list above indicates the No. of auxiliary contacts provided per contactor.

If larger motor starters are required, please turn to page 23.

EXPLANATION OF PART NUMBER SYSTEM

4 N W 0 A 0 # * @ @ K %

• **PRODUCT LINE**

4=Orange Line

• **OPERATION**

N=AC Coil
G=DC Coil

• **DESCRIPTION**

W=Non-Reversing Motor Starter
X=Reversing Motor Starter

• **FRAME SIZE**

• **FRAME ENCLOSURE**

0=Open Frame, No Enclosure

• **COIL VOLTAGE**

Select code from chart on next page

• **TERMINAL OPTION**

Blank: Standard
Y: Optional, non-removable terminal cover accessory. (Note: Y type not available for 0Q or 0R frame sizes)

• **OVERLOAD TYPE**

K=Open Phase Protection offered as a standard

• **QUANTITY OF AUX. CONTACTS**

10 : 1NO 20 : 2NO
01 : 1NC 02 : 2NC
11 : 1NO+1NC

See above under the "Qty. of Aux Contacts" column or next page.

• **OVERLOAD RANGE**

Select appropriate letter from chart on next page

"ORANGE LINE" AC Motor Starters, AC Operated

AVAILABLE COILS

Code Letter	AC Coil 60Hz	AC Coil 50Hz
E	24-26V	24V
F	48-52V	48V
A	100-110V	100V
1	110-120V	100-110V
G	120-130V	110-120V
B	200-220V	200V
2	220-240V	200-220V
C	400-440V	380-400V
4	440-480V	415-440V
5	550-600V	500-550V

If DC operation is required, please turn to page 14-15.

COIL CHARACTERISTICS

Frame Size	Power Consumption (VA)		Pick-up Voltage (V)	Drop-out Voltage (V)	Operating Time (ms)	
	Inrush Sealed				Coil ON	Coil OFF
					Contact ON	Contact OFF
0A	95	9	58-68	40-55	9-20	5-16
0F	95	9	58-68	40-55	9-20	5-16
0G	95	9	58-68	40-55	9-20	5-16
0Q	95	9	65-73	44-60	9-20	5-16
0R	95	9	65-73	44-60	9-20	5-16
0H	95	9	65-73	44-60	9-20	5-16

This data is based on 110-120VAC, 50/60Hz coil, tested at 120VAC, 60Hz. For additional coil data, please see page 51.

WIRING DIAGRAMS / AUXILIARY CONTACT INFORMATION

NON-REVERSING MOTOR STARTERS

(4NW0A0, 0F0, 0Q0 and 0R0)*

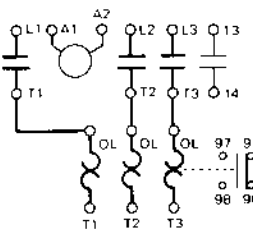

(4NW0G0 and 0H0)**

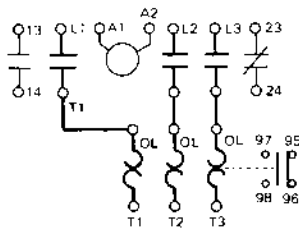

REVERSING MOTOR STARTERS

(4NX0A0, 0F0, 0Q0, 0R0)

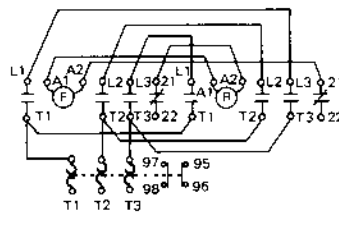

(4NX0G0, 0H0)

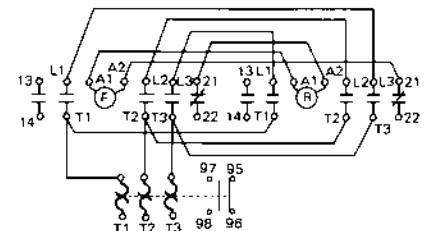

* The 0A, 0F, 0Q & 0R frames offer 1 Aux. contact, NO standard. However, NC is available as an option.

** The 0G & 0H frames offer 2 Aux. contacts, 1NO + 1NC standard. However, 2NO or 2NC is available as an option.

AUXILIARY CONTACT RATINGS

Operating	Contact rating Code Designation	Continuous Ampere Rating	Current-Make/Break (A)			
			110 to 120V	220 to 240V	440 to 480V	550 to 600V
AC	A600	10	60/6	30/3	15/1.5	12/1.2
DC	Q300	10	120V		240V	
			0.55/0.55		0.27/0.27	

OVERLOAD RANGES

Overload relays can be purchased separately. See page 13 for details and part numbers.

Code	Range	Code	Range	Code	Range	Code	Range
A	0.1-0.15	E	0.48-0.72	J	1.4-2.2	N	4-6
B	0.15-0.24	F	0.64-0.96	K	1.7-2.6	P	5-8
C	0.24-0.36	G	0.8-1.2	L	2.2-3.4	Q	6-9
D	0.36-0.54	H	0.95-1.45	M	2.8-4.2	S	7-11
						T†	9-13
						V†	12-18

† These codes (T & V) are not available on frame sizes 0A, 0F, or 0G. They can be specified for use on frame sizes 0Q, 0R, & 0H only.

"ORANGE LINE" AC Motor Starters, DC Operated



■ NON-REVERSING MOTOR STARTERS UL File No. E42419, E44592 cUL listed

1 Phase HP Rating (Full load ampere)		3 Phase HP Ratings (Full load ampere)				Rated thermal current for non inductive / resistive load	Qty. of Auxiliary Contacts	Part Number	Fuji Type	Frame Size
100-120V	220-240V	200-208V	220-240V	440-480V	550-600V					
1/3 (7.2)	1 (8)	2 (7.8)	2 (6.8)	5 (7.6)	5 (6.1)	11	1	4GW0A0#*@@K%	SW-03/G2E	0A
1/3 (7.2)	1 (8)	3 (11)	3 (9.6)	5 (7.6)	5 (6.1)	13	1	4GW0F0#*@@K%	SW-0/G2E	0F
1/3 (7.2)	1 (8)	3 (11)	3 (9.6)	5 (7.6)	5 (6.1)	13	2	4GW0G0#*@@K%	SW-05/G2E	0G
1 (16)	2 (12)	5 (17.5)	5 (15.2)	7 1/2 (11)	7 1/2 (9)	20	1	4GW0Q0#*@@K%	SW-4-0/G2E	0Q
1 (16)	2 (12)	5 (17.5)	5 (15.2)	10 (14)	10 (11)	20	1	4GW0R0#*@@K%	SW-4-1/G2E	0R
1 (16)	2 (12)	5 (17.5)	5 (15.2)	10 (14)	10 (11)	20	2	4GW0H0#*@@K%	SW-5-1/G2E	0H

■ REVERSING MOTOR STARTERS UL File No. E42419, E44592 cUL listed

1 Phase HP Rating (Full load ampere)		3 Phase HP Ratings (Full load ampere)				Rated thermal current for non inductive / resistive load	Qty. of Auxiliary Contacts	Part Number	Fuji Type	Frame Size
100-120V	220-240V	200-208V	220-240V	440-480V	550-600V					
1/3 (7.2)	1 (8)	2 (7.8)	2 (6.8)	5 (7.6)	5 (6.1)	11	1	4GX0A0#*@@K%	SW-03RM/G2E	0A
1/3 (7.2)	1 (8)	3 (11)	3 (9.6)	5 (7.6)	5 (6.1)	13	1	4GX0F0#*@@K%	SW-0RM/G2E	0F
1/3 (7.2)	1 (8)	3 (11)	3 (9.6)	5 (7.6)	5 (6.1)	13	2	4GX0G0#*@@K%	SW-05RM/G2E	0G
1 (16)	2 (12)	5 (17.5)	5 (15.2)	7 1/2 (11)	7 1/2 (9)	20	1	4GX0Q0#*@@K%	SW-4-0RM/G2E	0Q
1 (16)	2 (12)	5 (17.5)	5 (15.2)	10 (14)	10 (11)	20	1	4GX0R0#*@@K%	SW-4-1RM/G2E	0R
1 (16)	2 (12)	5 (17.5)	5 (15.2)	10 (14)	10 (11)	20	2	4GX0H0#*@@K%	SW-5-1RM/G2E	0H

Note: The list above indicates the No. of auxiliary contacts provided per contactor.

If larger motor starters are required, please turn to page 25.

EXPLANATION OF PART NUMBER SYSTEM

4 G W 0 A 0 # * @ @ K %

● **PRODUCT LINE**

4=Orange Line

● **OPERATION**

N=AC Coil
G=DC Coil

● **DESCRIPTION**

W=Non-Reversing Motor Starter
X=Reversing Motor Starter

● **FRAME SIZE**

● **FRAME ENCLOSURE**

0=Open Frame, No Enclosure

● **COIL VOLTAGE**

Select code from chart on next page

● **TERMINAL OPTION**

Blank: Standard
Y: Optional, non-removable terminal cover accessory. (Note: Y type not available for 0Q or 0R frame sizes)

● **OVERLOAD TYPE**

K=Open Phase Protection offered as a standard

● **QUANTITY OF AUX. CONTACTS**

10 : 1NO 20 : 2NO
01 : 1NC 02 : 2NC
11 : 1NO+1NC

See above under the "Qty. of Aux Contacts" column or next page.

● **OVERLOAD RANGE**

Select appropriate letter from chart on next page

"ORANGE LINE" AC Motor Starters, DC Operated

AVAILABLE COILS

Code Letter	DC Coil
T	12V
M	24V
N	48V
1	100V
R	110V
2	200V
S	220V

If AC operation is required, please turn to page 12-13.

COIL CHARACTERISTICS

Frame Size	Power Consumption (VA)		Pick-up Voltage (V)	Drop-out Voltage (V)	Operating Time (ms)	
	Inrush Sealed				Coil ON ↓ Contact ON	Coil OFF ↓ Contact OFF
0A	7	7	11-15	3-6	43-47	22-24
0F	7	7	11-15	3-6	43-47	22-24
0G	7	7	10-15	3-7	43-47	22-24
0Q	7	7	11-15	3-7	44-48	22-25
0R	7	7	11-15	3-7	44-48	22-25
0H	7	7	11-16	4-7	45-49	22-26

This data is based on 24-26VDC coil, tested at 24VDC. For additional coil data, please see page 52.

WIRING DIAGRAMS / AUXILIARY CONTACT INFORMATION

NON-REVERSING MOTOR STARTERS

(4NW0A0, 0F0, 0Q0 and 0R0)*

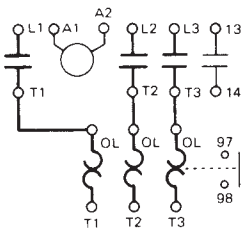

(4GW0G0 and 0H0)**

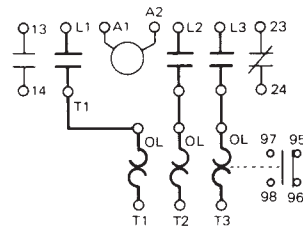

REVERSING MOTOR STARTERS

(4GX0A0, 0F0, 0Q0, 0R0)

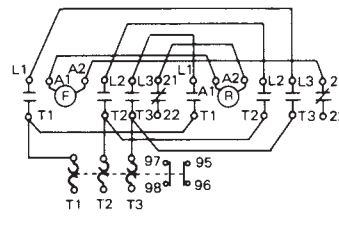

(4GX0G0, 0H0)

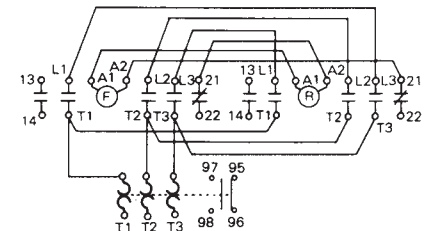

- * The 0A, 0F, 0Q & 0R frames offer 1 Aux. contact, NO standard. However, NC is available as an option.
 ** The 0G & 0H frames offer 2 Aux. contacts, 1NO + 1NC standard. However, 2NO or 2NC is available as an option.

AUXILIARY CONTACT RATINGS

Operating	Contact rating code designation	Continuous ampere rating	Current-Make/Break (A)			
			110 to 120V	220 to 240V	440 to 480V	550 to 600V
AC	A600	10	60/6	30/3	15/1.5	12/1.2
DC	Q300	10	120V		240V	
			0.55/0.55		0.27/0.27	

OVERLOAD RANGES

Code	Range	Code	Range	Code	Range	Code	Range	Code	Range
A	0.1-0.15	E	0.48-0.72	J	1.4-2.2	N	4-6	T†	9-13
B	0.15-0.24	F	0.64-0.96	K	1.7-2.6	P	5-8	V†	12-18
C	0.24-0.36	G	0.8-1.2	L	2.2-3.4	Q	6-9		
D	0.36-0.54	H	0.95-1.45	M	2.8-4.2	S	7-11		

† These codes (T & V) are not available on frame sizes 0A, 0F, or 0G. They can be specified for use on frame sizes 0Q, 0R, & 0H only.

Overload relays can be purchased separately. See page 13 for details and part numbers.

"ORANGE LINE" THERMAL OVERLOAD RELAYS

Selection Guide

FEATURES

- 1NO+1NC alarm contact (Automatic reset available.)
- Provided with a built-in heater, thus ensuring accurate operations.
- Calibrated Rated Current Dial.
- With manual trip device.
- With open-phase protection device.



THERMAL OVERLOAD RELAYS UL File No.E44592 CSA File No.LR20479

Overload Part#	Ampere Range Code Letter	Adjustable Ampere Range	Used on Contactor Frames	Japanese Part Number for Overload
4NK0A*%	A	0.1 – 0.15	0A, 0F, 0G	TK-0N
	B	0.15 – 0.24		
	C	0.24 – 0.36		
	D	0.36 – 0.54		
	E	0.48 – 0.72		
	F	0.64 – 0.96		
	G	0.8 – 1.2		
	H	0.95 – 1.45		
	J	1.4 – 2.2		
	K	1.7 – 2.6		
	L	2.2 – 3.4		
	M	2.8 – 4.2		
	N	4 – 6		
	P	5 – 8		
Q	6 – 9			
S	7 – 11			
4NK0H*%	A	0.1 – 0.15	0Q, 0R, 0H	TK-5-1N
	B	0.15 – 0.24		
	C	0.24 – 0.36		
	D	0.36 – 0.54		
	E	0.48 – 0.72		
	F	0.64 – 0.96		
	G	0.8 – 1.2		
	H	0.95 – 1.45		
	J	1.4 – 2.2		
	K	1.7 – 2.6		
	L	2.2 – 3.4		
	M	2.8 – 4.2		
	N	4 – 6		
	P	5 – 8		
	Q	6 – 9		
	S	7 – 11		
	T	9 – 13		
	V	12 – 18		

EXPLANATION OF PART NUMBER SYSTEM

4 N K 0 A * %

● **PRODUCT LINE**

4N= Orange Line

● **STYLE**

K=Open Phase Protection offered as a standard

● **ENCLOSURE**

0=None, Open Frame

● **TERMINAL OPTION**

Blank: Standard
Y: Optional, non-removable terminal cover accessory.

● **AMPERE RANGE CODE**

See above chart

● **FRAME SIZE**

A or H

"ORANGE LINE" THERMAL OVERLOAD RELAYS

Overload Trip Curves

■ THERMAL OVERLOAD RELAYS/OPEN-PHASE PROTECTION TYPE K

Cold Start

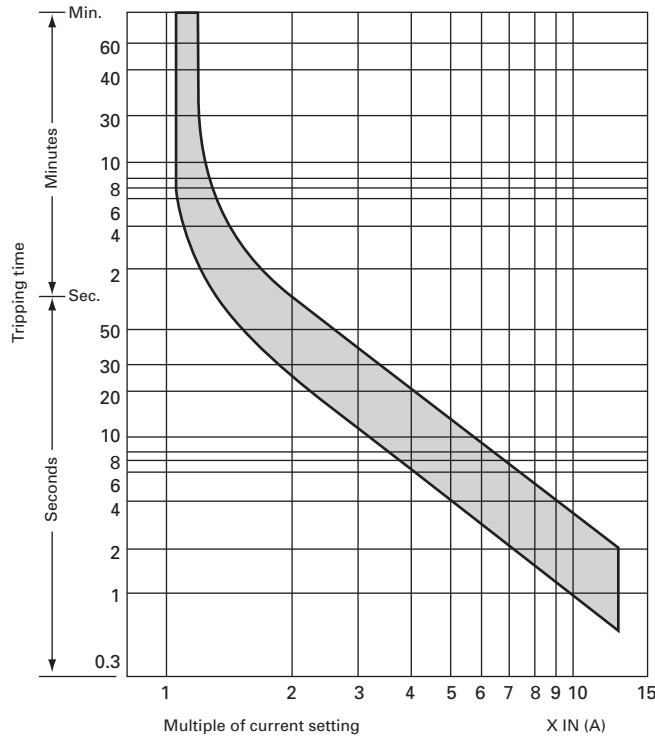

Hot Start

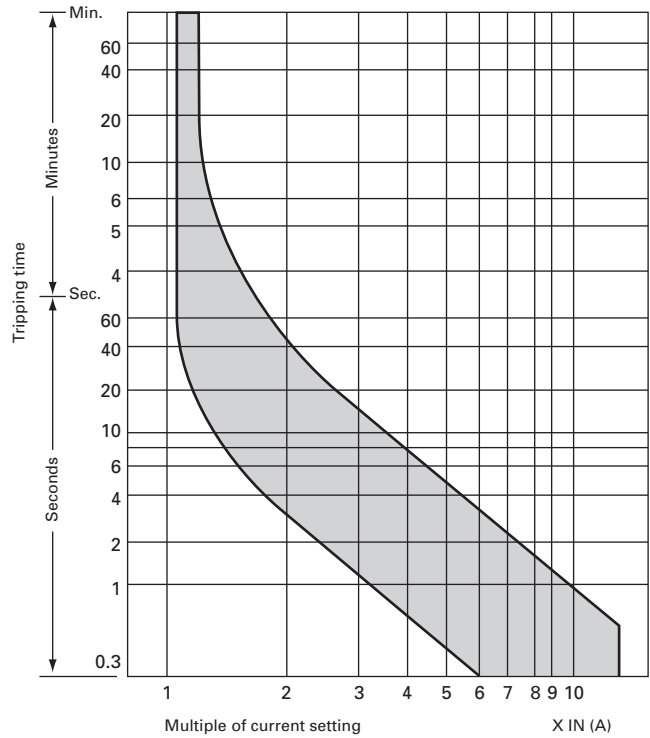

Cat. No.: 4NK0A*, 4NK0H*
FUJI type: TK-0N, TK-5-1N

■ AMBIENT TEMPERATURE COMPENSATOR

FUJI overload relays are provided with an ambient temperature compensator. Their characteristics limit ampere value changes to approx. 10% as the ambient temperature changes between -5°C and 40°C.

Compensation characteristics
(Average value)

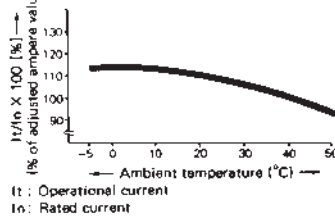

■ WIRING DIAGRAMS

(4NK0A* through 4NK4Q*)

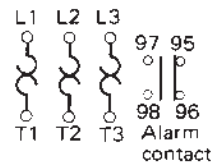

Independent mounting of Orange Line thermal overload relays is possible through the use of an additional mounting bracket.

For 4NK0A* overloads, use mounting bracket part # SZ-HB
For 4NK0H* overloads, use mounting bracket part # SZ-HC

■ ALARM CONTACT RATINGS

Contact rating Code Designation	Continuous Ampere Rating	Current-Make/Break (A)			
		110 to 120V	220 to 240V	440 to 480V	550 to 600V
C600	2.5	15/1.5	7.5/0.75	3.75/0.375	3.0/0.3

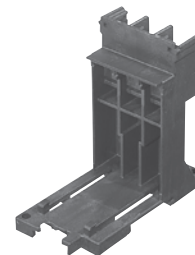

Base unit for separate mounting

"ORANGE LINE" ACCESSORIES

SIDE MOUNTING

■ AUXILIARY CONTACT BLOCK

Single pole (1NO + 1NC)

■ MECHANICAL INTERLOCK UNIT

The mechanical interlock unit is used to interlock two contactors for reversing. One size fits all contactors.

■ MAIN CIRCUIT SURGE SUPPRESSION UNIT

This unit prevents mis-operation of electronic controllers due to surge voltages.

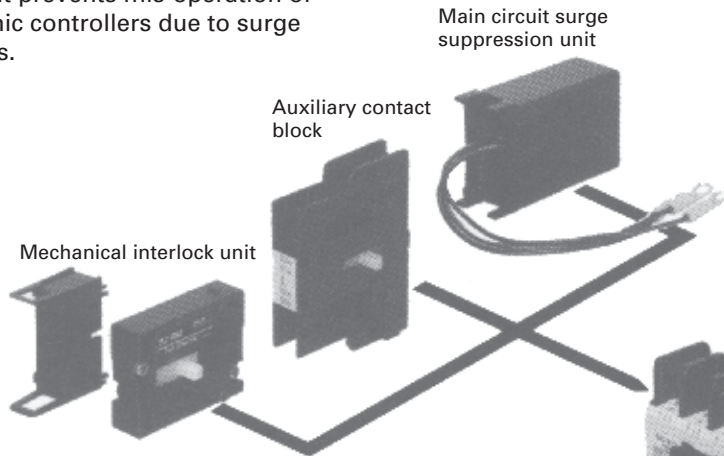

Coil drive unit*

Coil surge suppression unit

TOP MOUNTING

■ COIL DRIVE UNIT

This unit controls ON-OFF operation for magnetic contactors with output from electronic equipment.

■ COIL SURGE SUPPRESSION UNIT

This unit absorbs coil surge voltage due to contactor ON-OFF operations.

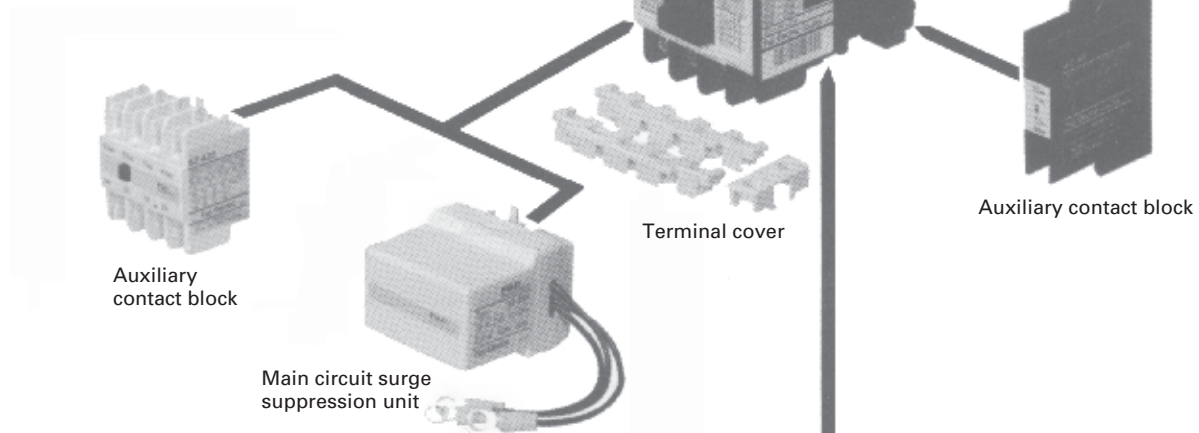

FRONT MOUNTING

■ AUXILIARY CONTACT BLOCK

2-pole or 4-pole

■ MAIN CIRCUIT SURGE SUPPRESSION UNIT

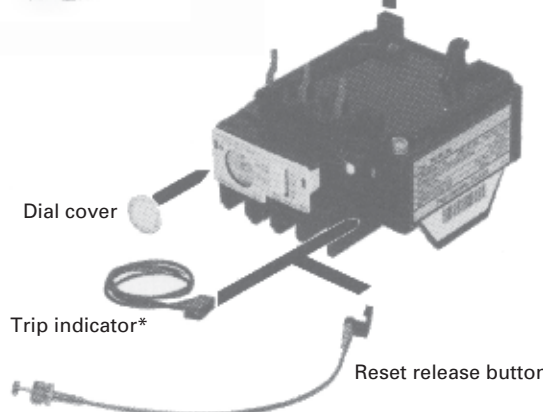

Note:

*: These accessories can be mounted on contactor or starter. However UL and CSA does not approve these combinations as UL Listed or CSA Certified products.

"ORANGE LINE" ACCESSORIES

Description	Type	
Auxiliary Contact Block	• Front mounting	
	4NO	SZ-A40
	3NO+1NC	SZ-A31
	2NO+2NC	SZ-A22
	2NO	SZ-A20
	1NO+1NC	SZ-A11
	2NC	SZ-A02
	1NO+1NC (Over lapping)	SZ-A111
	2NO+2NC (Over lapping)	SZ-A222
	• Front mounting, single contact type	
	4NO	SZ-A40H
	3NO+1NC	SZ-A31H
	2NO+2NC	SZ-A22H
	• Side mounting	
	1NO+1NC	SZ-AS1
• Side mounting, single contact type	SZ-AS1H	

Note: Front mounting type and side mounting type auxiliary contact blocks cannot be used simultaneously.

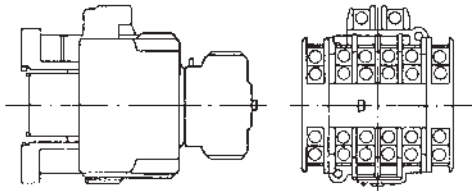

3-pole Parallel Connection Link	For 0A0, 0F0, 0G0 (2 pcs.)	SZ-SP1
	For 0Q0, 0R0, 0H0 (2 pcs.)	SZ-SP2
Coil Drive Unit	24V DC (Relay)	SZ-CD1
	24V DC (Solid State)	SZ-03/ CD2-24
Off-delay Release Unit	100V AC	SZ-DE100
	110V AC	SZ-DE110
	200V AC	SZ-DE200
	220V AC	SZ-DE220

Description	Type	
Terminal Cover	• Contactor For 4NC0A0, 4NC0F0, 4SH4 For 4NC0G0, 4SH5 For 4NC0Q0, 4NC0R0 For 4NC0H0	SZ-T1 SZ-T2 SZ-T3 SZ-T4
	• Auxiliary contact block For 4-pole, front mounting ^{*1} For 2-pole, front mounting For 2-pole, side mounting	SZ-T5 SZ-T6 SZ-T7
	• Thermal overload relay For 4NK0A For 4NK0H Base unit for separate mounting: For SZ-HB For SZ-HC	SZ-T12 SZ-T13 SZ-T10 SZ-T11
Coil Surge Suppression Unit	Varistor: 24 to 48V AC/DC 100 to 240V AC/DC 380 to 440V AC/DC 24 to 48V AC/DC with LED 100 to 240V AC/DC with LED RC: 24 to 48V AC/DC 100 to 240V AC/DC 24 to 48V AC/DC with LED 100 to 240V AC/DC with LED	SZ-Z1 SZ-Z2 SZ-Z3 SZ-Z6 SZ-Z7 SZ-Z4 SZ-Z5 SZ-Z8 SZ-Z9
Main Circuit Surge Suppression Unit	With delta-connected CR, 100 to 240V AC • Front mounting • Side mounting	SZ-ZM1 SZ-ZM2
Base Unit for Separate Mounting	For 4NK0A For 4NK0H	SZ-HB SZ-HC
Case Cover	Non-reversing (Plastic)	SZ-JC1
	Non-reversing, with pushbuttons (Plastic)	SZ-JC2
	Reversing (Steel)	SZ-JC3
Dial Cover		SZ-DA
Trip Indicator	100 to 110V AC 200 to 220V AC	SZ-L100 SZ-L200
Reset Release Button	Lead length: 300mm	SZ-R1
	500mm	SZ-R2
	700mm	SZ-R3
Mechanical Interlock Unit		SZ-RM
Power Connection Kit for Reversing	For 4NC0A0, 4NC0F0	SZ-RW1
	For 4NC0G0	SZ-RW2
	For 4NC0Q0, 4NC0R0	SZ-RW3
	For 4NC0H0	SZ-RW4

*1: Terminal cover used for 4SH8 Industrial Relay

ORANGE LINE REPLACEMENT PARTS

MAIN CONTACTS

Size	Contacts	Kit Each	U.S. Catalog No.
0A	Movable	3	4NC0A-CK
	Stationary	6	
0F, 0G	Movable	3	4NC0G-CK
	Stationary	6	
0Q	Movable	3	4NC0Q-CK
	Stationary	6	
0R, 0H	Movable	3	4NC0H-CK
	Stationary	6	

COIL

ALL ORANGE LINE devices use the same coils.

-AC coils: 4NC0H-#MC, Replace the # with the correct coil code found on page 9

Note: Auxiliary contact blocks, terminal covers, & coil surge suppression units are also usable with Orange Line Industrial Relays (page 54)

"ORANGE LINE" Dimensions

■ NON-REVERSING CONTACTORS/OPEN TYPE Approximate Dimensions, mm

FIG.1 (4NC0A0 through 4NC0H0)

4NC0A0, 0F0, 0Q0, 0R0

4NC0G0, 0H0

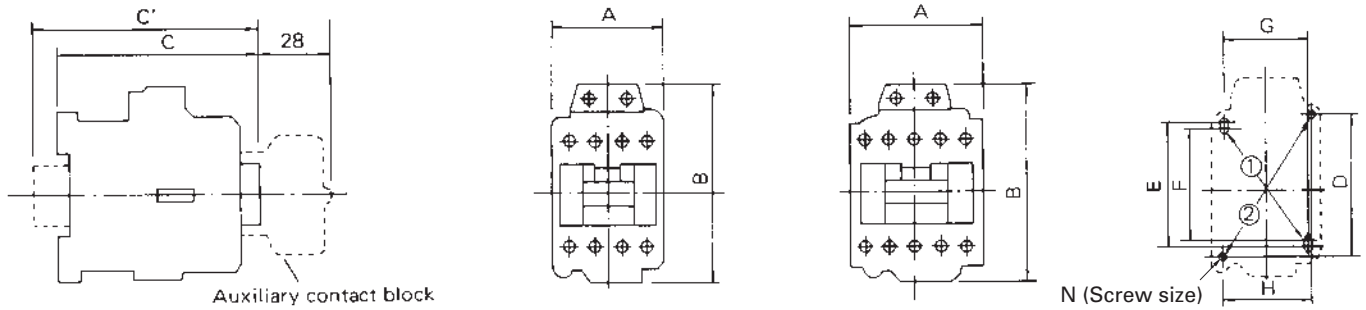

U.S. CAT. No.	Fuji Type	Fig. No.	Dimensions, mm										Net Weight (kg)
			A	B	C	C'	D	E	F	G	H	N	
4NC0A0	SC-03	1	43	80	80	90	60	52	48	34	35	2-M4	0.32
4NC0F0	SC-0	1	43	80	80	90	60	52	48	34	35	2-M4	0.32
4NC0G0	SC-05	1	53	80	80	90	60	52	48	34	35	2-M4	0.34
4NC0Q0	SC-4-0	1	53	80	81	91	60	52	48	34	35	2-M4	0.36
4NC0R0	SC-4-1	1	53	80	81	91	60	52	48	34	35	2-M4	0.36
4NC0H0	SC-5-1	1	64	80	81	91	60	60	56	54	50	2-M4	0.38
4GC0A0	SC-03/G	1	43	80	110	120	60	52	48	34	35	2-M4	0.55
4GC0F0	SC-0/G	1	43	80	110	120	60	52	48	34	35	2-M4	0.55
4GC0G0	SC-05/G	1	53	80	110	120	60	52	48	34	35	2-M4	0.58
4GC0Q0	SC-4-0/G	1	53	80	111	121	60	52	48	34	35	2-M4	0.6
4GC0R0	SC-4-1/G	1	53	80	111	121	60	52	48	34	35	2-M4	0.6
4GC0H0	SC-5-1/G	1	64	80	111	121	60	60	56	54	50	2-M4	0.62

FIG.2 (4NW0A0 through 4NW0H0)

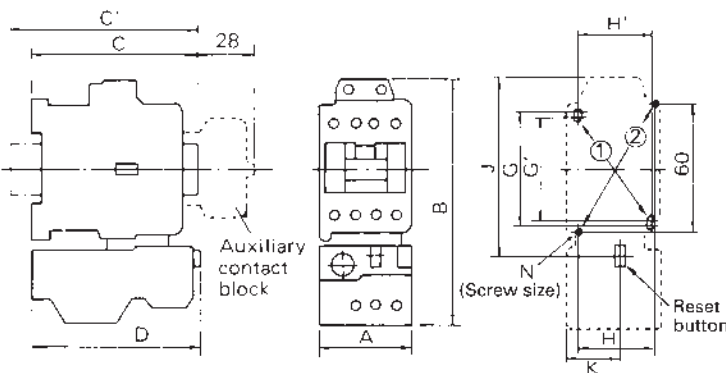

U.S. CAT. No.	Fuji Type	Fig. No.	Dimensions, mm													Net Weight (kg)
			A	B	C	C'	D	F	G	G'	H	H'	J	K	N	
4NW0A0	SW-03/2E	2	44	120	80	90	81	60	52	48	35	34	90	26.5	2-M4	0.43
4NW0F0	SW-0/2E	2	44	120	80	90	81	60	52	48	35	34	90	26.5	2-M4	0.43
4NW0G0	SW-05/2E	2	53	120	80	90	81	60	52	48	35	34	90	35.5	2-M4	0.45
4NW0Q0	SW-4-0/2E	2	53	126	81	91	81	60	52	48	35	34	93	26.5	2-M4	0.47
4NW0R0	SW-4-1/2E	2	53	126	81	91	81	60	52	48	35	34	93	26.5	2-M4	0.47
4NW0H0	SW-5-1/2E	2	64	126	81	91	81	60	60	56	50	54	93	37.5	2-M4	0.5
4GW0A0	SW-03/G 2E	2	44	120	110	120	81	60	52	48	35	34	90	26.5	2-M4	0.66
4GW0F0	SW-0/G 2E	2	44	120	110	120	81	60	52	48	35	34	90	26.5	2-M4	0.66
4GW0G0	SW-05/G 2E	2	53	120	110	120	81	60	52	48	35	34	90	35.5	2-M4	0.69
4GW0Q0	SW-4-0/G 2E	2	53	126	111	121	81	60	52	48	35	34	93	26.5	2-M4	0.72
4GW0R0	SW-4-1/G 2E	2	53	126	111	121	81	60	52	48	35	34	93	26.5	2-M4	0.72
4GW0H0	SW-5-1/G 2E	2	64	126	111	121	81	60	60	56	50	54	93	37.5	2-M4	0.74

"ORANGE LINE" Dimensions

REVERSING CONTACTORS/OPEN TYPE Approximate Dimensions, mm

FIG.3 (4ND0A0 through 4ND0H0)

4ND0A0, 0F0, 0Q0, 0R0

4ND0G0, 0H0

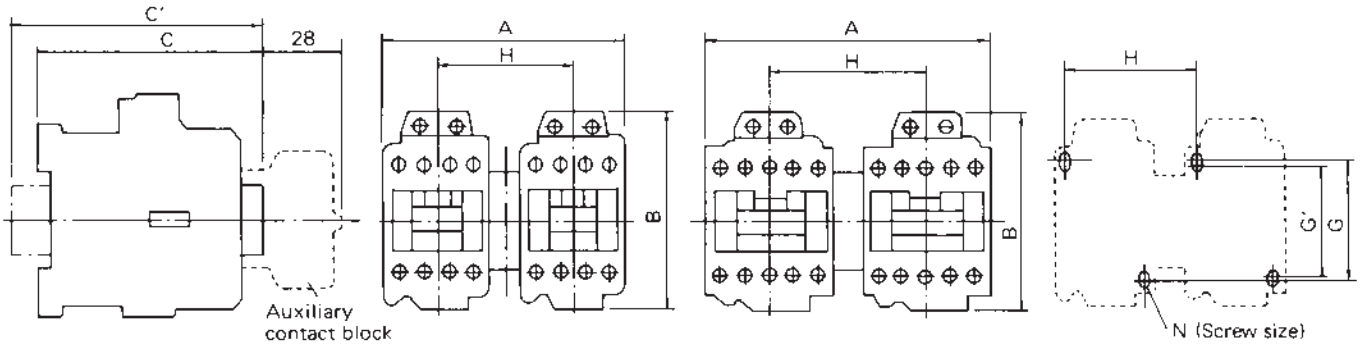

U.S. CAT. No.	Fuji Type	Fig. No.	Dimensions, mm								Net Weight (kg)
			A	B	C	C'	G	G'	H	N	
4ND0A0	SC-03RM	3	99	80	80	90	52	48	56	4-M4	0.68
4ND0F0	SC-0RM	3	99	80	80	90	52	48	56	4-M4	0.68
4ND0G0	SC-05RM	3	119	80	80	90	52	48	66	4-M4	0.72
4ND0Q0	SC-4-0RM	3	119	80	81	91	52	48	66	4-M4	0.76
4ND0R0	SC-4-1RM	3	119	80	81	91	52	48	66	4-M4	0.76
4ND0H0	SC-5-1RM	3	141	80	81	91	60	56	77	4-M4	0.8
4GD0A0	SC-03RM/G	3	99	80	110	120	52	48	56	4-M4	1.14
4GD0F0	SC-0RM/G	3	99	80	110	120	52	48	56	4-M4	1.14
4GD0G0	SC-05RM/G	3	119	80	110	120	52	48	66	4-M4	1.20
4GD0Q0	SC-4-0RM/G	3	119	80	111	121	52	48	66	4-M4	1.24
4GD0R0	SC-4-1RM/G	3	119	80	111	121	52	48	66	4-M4	1.24
4GD0H0	SC-5-1RM/G	3	141	80	111	121	60	56	77	4-M4	1.28

REVERSING MOTOR STARTERS/OPEN TYPE Approximate Dimensions, mm

FIG.4 (4NX0A0 through 4NX0H0)

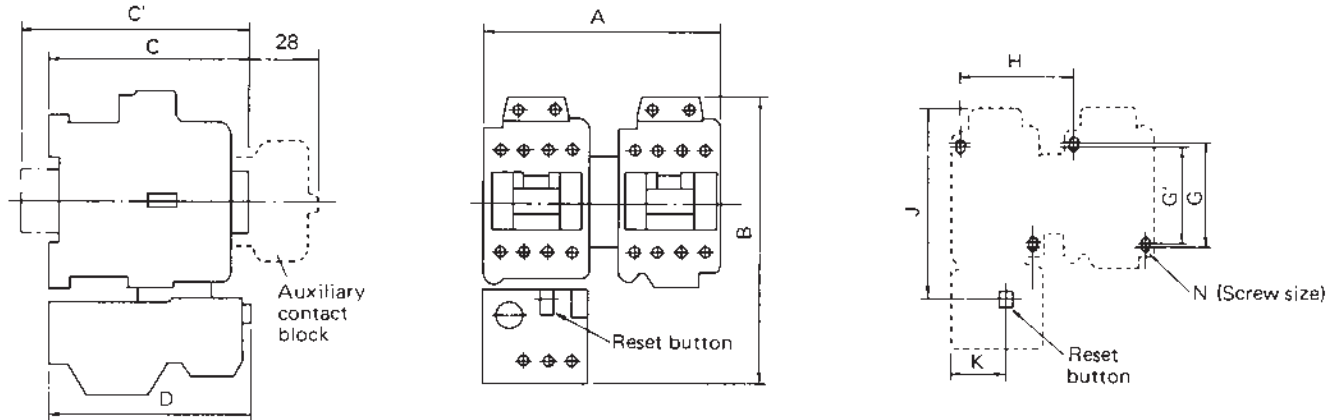

U.S. CAT. No.	Fuji Type	Fig. No.	Dimensions, mm											Net Weight (kg)
			A	B	C	C'	D	G	G'	H	J	K	N	
4NX0A0	SW-03RM/2E	4	100	120	80	90	81	52	48	56	90	26.5	4-M4	0.79
4NX0F0	SW-0RM/2E	4	100	120	80	90	81	52	48	56	90	26.5	4-M4	0.79
4NX0G0	SW-05RM/2E	4	119	120	80	90	81	52	48	66	90	35.5	4-M4	0.83
4NX0Q0	SW-4-0RM/2E	4	119	126	81	91	81	52	48	66	93	26.5	4-M4	0.87
4NX0R0	SW-4-1RM/2E	4	119	126	81	91	81	52	48	66	93	26.5	4-M4	0.87
4NX0H0	SW-5-1RM/2E	4	141	126	81	91	81	60	56	77	93	37.5	4-M4	0.92
4GX0A0	SW-03RM/G 2E	4	100	120	110	120	81	52	48	56	90	26.5	4-M4	1.24
4GX0F0	SW-0RM/G 2E	4	100	120	110	120	81	52	48	56	90	26.5	4-M4	1.24
4GX0G0	SW-05RM/G 2E	4	119	120	110	120	81	52	48	66	90	35.5	4-M4	1.30
4GX0Q0	SW-4-0RM/G 2E	4	119	120	111	121	81	52	48	66	93	26.5	4-M4	1.40
4GX0R0	SW-4-1RM/G 2E	4	119	120	111	121	81	52	48	66	93	26.5	4-M4	1.40
4GX0H0	SW-5-1RM/G 2E	4	141	120	111	121	81	60	56	77	93	37.5	4-M4	1.42

"ORANGE LINE" Dimensions

■ THERMAL OVERLOAD RELAYS Approximate Dimensions, mm

FIG. 5

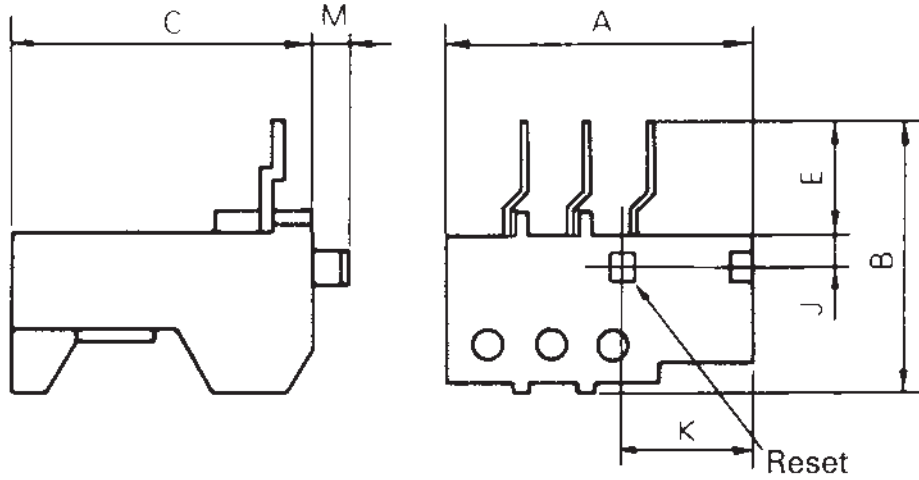

U.S. CAT. No.	Fuji Type	Fig. No.	Dimensions, mm							Net Weight (kg)
			A	B	C	E	J	K	M	
4NK0A*	TK-0N	5	44	58.5	77	17	10.5	17.5	3	0.11
4NK0H*	TK-5-1N	5	53	60.5	77	14	14	26.5	3	0.12

Schematic Diagram

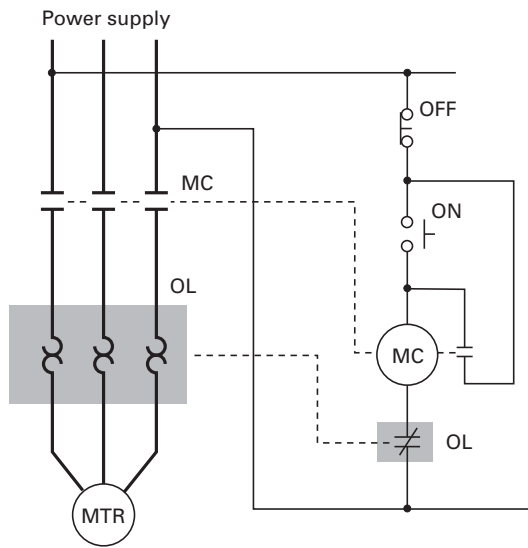

"ODYSSEY SERIES" AC Contactors & Starters, AC Operated (Conventional AC Coils)

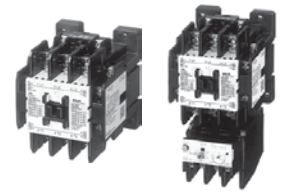

■ NON-REVERSING CONTACTORS UL File No. E42419

1 Phase HP Rating (Full load ampere)		3 Phase HP Ratings (Full load ampere)				Rated thermal current for non inductive / resistive load	Qty. of Aux. Contacts		Part Number	Fuji Type	Frame Size
100-120V	220-240V	200-208V	220-240V	440-480V	550-600V		NO	NC			
2 (24)	5 (28)	7 1/2 (25.3)	10 (28)	25 (34)	25 (27)	50	2	2	3NC0T0#22	SC-N1	0T
3 (34)	7 1/2 (40)	10 (32.2)	15 (42)	30 (40)	30 (32)	60	2	2	3NC1Q0#22	SC-N2	1Q
3 (34)	10 (50)	15 (48.3)	20 (54)	40 (52)	40 (41)	80	2	2	3NC2F0#22	SC-N2S	2F
5 (34)	15 (68)	20 (62.1)	25 (68)	50 (65)	50 (52)	100	2	2	3NC2H0#22	SC-N3	2H
7 1/2 (56)	15 (68)	25 (78.2)	30 (80)	60 (77)	60 (62)	135	2	2	3NC2T0#22	SC-N4	2T

■ REVERSING CONTACTORS UL File No. E42419, cUL listed

1 Phase HP Rating (Full load ampere)		3 Phase HP Ratings (Full load ampere)				Rated thermal current for non inductive / resistive load	Qty. of Aux. Contacts		Part Number	Fuji Type	Frame Size
100-120V	220-240V	200-208V	220-240V	440-480V	550-600V		NO	NC			
2 (24)	5 (28)	7 1/2 (25.3)	10 (28)	25 (34)	25 (27)	50	2	2	3ND0T0#22	SC-N1RM	0T
3 (34)	7 1/2 (40)	10 (32.2)	15 (42)	30 (40)	30 (32)	60	2	2	3ND1Q0#22	SC-N2RM	1Q
3 (34)	10 (50)	15 (48.3)	20 (54)	40 (52)	40 (41)	80	2	2	3ND2F0#22	SC-N2SRM	2F
5 (34)	15 (68)	20 (62.1)	25 (68)	50 (65)	50 (52)	100	2	2	3ND2H0#22	SC-N3RM	2H
7 1/2 (56)	15 (68)	25 (78.2)	30 (80)	60 (77)	60 (62)	135	2	2	3ND2T0#22	SC-N4RM	2T

■ NON-REVERSING MOTOR STARTERS UL File No. E42419, cUL listed

1 Phase HP Rating (Full load ampere)		3 Phase HP Ratings (Full load ampere)				Rated thermal current for non inductive / resistive load	Qty. of Aux. Contacts		Part Number	Fuji Type	Frame Size
100-120V	220-240V	200-208V	220-240V	440-480V	550-600V		NO	NC			
2 (24)	5 (28)	7 1/2 (25.3)	10 (28)	25 (34)	25 (27)	50	2	2	3NW0T0#*22K	SW-N1/2E	0T
3 (34)	7 1/2 (40)	10 (32.2)	15 (42)	30 (40)	30 (32)	60	2	2	3NW1Q0#*22K	SW-N2/2E	1Q
3 (34)	10 (50)	15 (48.3)	20 (54)	40 (52)	40 (41)	80	2	2	3NW2F0#*22K	SW-N2S/2E	2F
5 (34)	15 (68)	20 (62.1)	25 (68)	50 (65)	50 (52)	100	2	2	3NW2H0#*22K	SW-N3/2E	2H
7 1/2 (56)	15 (68)	25 (78.2)	30 (80)	60 (77)	60 (62)	135	2	2	3NW2T0#*22K	SW-N4/2E	2T

■ REVERSING MOTOR STARTERS UL File No. E42419, cUL listed

1 Phase HP Rating (Full load ampere)		3 Phase HP Ratings (Full load ampere)				Rated thermal current for non inductive / resistive load	Qty. of Aux. Contacts		Part Number	Fuji Type	Frame Size
100-120V	220-240V	200-208V	220-240V	440-480V	550-600V		NO	NC			
2 (24)	5 (28)	7 1/2 (25.3)	10 (28)	25 (34)	25 (27)	50	2	2	3NX0T0#*22K	SW-N1RM/2E	0T
3 (34)	7 1/2 (40)	10 (32.2)	15 (42)	30 (40)	30 (32)	60	2	2	3NX1Q0#*22K	SW-N2RM/2E	1Q
3 (34)	10 (50)	15 (48.3)	20 (54)	40 (52)	40 (41)	80	2	2	3NX2F0#*22K	SW-N2SRM/2E	2F
5 (34)	15 (68)	20 (62.1)	25 (68)	50 (65)	50 (52)	100	2	2	3NX2H0#*22K	SW-N3RM/2E	2H
7 1/2 (56)	15 (68)	25 (78.2)	30 (80)	60 (77)	60 (62)	135	2	2	3NX2T0#*22K	SW-N4RM/2E	2T

If larger contactors or motor starters are required, please turn to page 27-30.

EXPLANATION OF PART NUMBER SYSTEM

3 N W 0 T 0 # * 2 2 K

● **PRODUCT LINE**
3=Odyssey Series

● **OPERATION**
N=AC Coil

● **DESCRIPTION**
C=Non-Reversing Contactor
D=Reversing Contactor
W=Non-Reversing Motor Starter
X=Reversing Motor Starter

● **FRAME SIZE**

● **FRAME ENCLOSURE**
0=Open Frame, No Enclosure

● **OVERLOAD TYPE**
K=Open Phase Protection
offered as a standard
(motor starters only
omit for contactors)

● **QUANTITY OF N.C. AUX. CONTACTS**

● **QUANTITY OF N.O. AUX. CONTACTS**

● **OVERLOAD RANGE**
Select appropriate letter from chart
on page 31
(motor starters only
omit for contactors)

● **COIL VOLTAGE**
Select code from chart on next page

"ODYSSEY SERIES" AC Contactors & Starters, AC Operated (Conventional AC Coils)

AVAILABLE COILS

Code Letter	AC Coil 60Hz	AC Coil 50Hz
E	24-26V	24V
F	48-52V	48V
A	100-110V	100V
1	110-120V	100-110V
G	120-130V	110-120V
B	200-220V	200V
2	220-240V	200-220V
C	400-440V	380-400V
4	440-480V	415-440V
5	550-600V	500-550V

If DC operation is required,
please turn to page 25-26.

COIL CHARACTERISTICS

Frame Size	Power Consumption (VA)		Pick-up Voltage (V)	Drop-out Voltage (V)	Operating Time (ms)	
					Coil ON	Coil OFF
Inrush Sealed						
			Contact ON	Contact OFF		
0T	135	12.4	60-70	43-58	10-17	6-13
1Q	135	12.4	60-70	43-58	10-17	6-13
2F	190	13.4	65-75	50-60	10-18	8-18
2H	190	13.4	65-75	50-60	10-18	8-18
2T	210	14.4	70-75	51-53	16-23	7-17

This data is based on 110-120VAC, 50/60Hz coil, tested at 120VAC, 60Hz.
For additional coil data, please see page 51.

WIRING DIAGRAMS / AUXILIARY CONTACT INFORMATION

NON-REVERSING CONTACTORS



NON-REVERSING MOTOR STARTERS

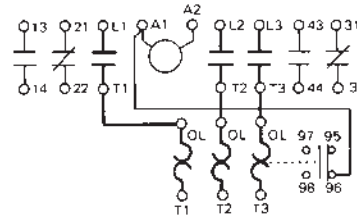

REVERSING CONTACTORS

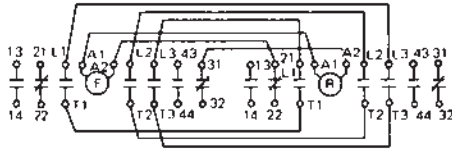

REVERSING MOTOR STARTERS

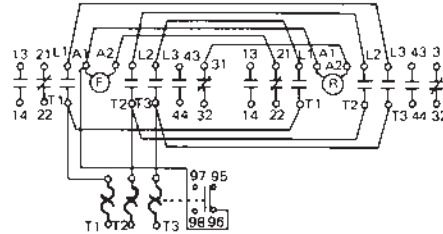

AUXILIARY CONTACT RATINGS

Operating	Contact rating Code Designation	Continuous Ampere Rating	Current-Make/Break (A)			
			110 to 120V	220 to 240V	440 to 480V	550 to 600V
AC	A600	10	60/6	30/3	15/1.5	12/1.2
DC	Q300	10	120V	240V		
			0.55/0.55	0.27/0.27		

Notes:

- All Odyssey series contactors and starters come equipped with 2NO + 2NC auxiliary contacts standard.
- Reversing contactors & starters from Frame size 0T through 2H can be constructed in the field. See accessories on pages 33-34 for details. Large frame size reversing units only factory assembled.

"ODYSSEY SERIES" AC Contactors & Starters, DC Operated (Conventional DC Coils)

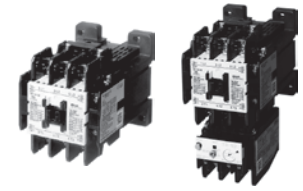

■ NON-REVERSING CONTACTORS UL File No. E42419, cUL listed

1 Phase HP Rating (Full load ampere)		3 Phase HP Ratings (Full load ampere)				Rated thermal current for non inductive / resistive load	Qty. of Aux. Contacts		Part Number	Fuji Type	Frame Size
100-120V	220-240V	200-208V	220-240V	440-480V	550-600V		NO	NC			
2 (24)	5(28)	71/2 (25.3)	10 (28)	25 (34)	25 (27)	50	2	2	3GC0T0#22	SC-N1/G	0T
3 (34)	71/2(40)	10 (32.2)	15 (42)	30 (40)	30 (32)	60	2	2	3GC1Q0#22	SC-N2/G	1Q
3 (34)	10(50)	15 (48.3)	20 (54)	40 (52)	40 (41)	80	2	2	3GC2F0#22	SC-N2S/G	2F
5 (34)	15(68)	20 (62.1)	25 (68)	50 (65)	50 (52)	100	2	2	3GC2H0#22	SC-N3/G	2H

■ REVERSING CONTACTORS UL File No. E42419, cUL listed

1 Phase HP Rating (Full load ampere)		3 Phase HP Ratings (Full load ampere)				Rated thermal current for non inductive / resistive load	Qty. of Aux. Contacts		Part Number	Fuji Type	Frame Size
100-120V	220-240V	200-208V	220-240V	440-480V	550-600V		NO	NC			
2 (24)	5 (28)	71/2 (25.3)	10 (28)	25 (34)	25 (27)	50	2	2	3GD0T0#22	SC-N1RM/G	0T
3 (34)	71/2 (40)	10 (32.2)	15 (42)	30 (40)	30 (32)	60	2	2	3GD1Q0#22	SC-N2RM/G	1Q
3 (34)	10 (50)	15 (48.3)	20 (54)	40 (52)	40 (41)	80	2	2	3GD2F0#22	SC-N2SRM/G	2F
5 (34)	15 (68)	20 (62.1)	25 (68)	50 (65)	50 (52)	100	2	2	3GD2H0#22	SC-N3RM/G	2H

■ NON-REVERSING MOTOR STARTERS UL File No. E42419, cUL listed

1 Phase HP Rating (Full load ampere)		3 Phase HP Ratings (Full load ampere)				Rated thermal current for non inductive / resistive load	Qty. of Aux. Contacts		Part Number	Fuji Type	Frame Size
100-120V	220-240V	200-208V	220-240V	440-480V	550-600V		NO	NC			
2 (24)	5 (28)	71/2 (25.3)	10 (28)	25 (34)	25 (27)	50	2	2	3GW0T0#*22K	SW-N1/G2E	0T
3 (34)	71/2 (40)	10 (32.2)	15 (42)	30 (40)	30 (32)	60	2	2	3GW1Q0#*22K	SW-N2/G2E	1Q
3 (34)	10 (50)	15 (48.3)	20 (54)	40 (52)	40 (41)	80	2	2	3GW2F0#*22K	SW-N2S/G2E	2F
5 (34)	15 (68)	20 (62.1)	25 (68)	50 (65)	50 (52)	100	2	2	3GW2H0#*22K	SW-N3/G2E	2H

■ REVERSING MOTOR STARTERS UL File No. E42419, cUL listed

1 Phase HP Rating (Full load ampere)		3 Phase HP Ratings (Full load ampere)				Rated thermal current for non inductive / resistive load	Qty. of Aux. Contacts		Part Number	Fuji Type	Frame Size
100-120V	220-240V	200-208V	220-240V	440-480V	550-600V		NO	NC			
2 (24)	5 (28)	71/2 (25.3)	10 (28)	25 (34)	25 (27)	50	2	2	3GX0T0#*22K	SW-N1RM/G2E	0T
3 (34)	71/2 (40)	10 (32.2)	15 (42)	30 (40)	30 (32)	60	2	2	3GX1Q0#*22K	SW-N2RM/G2E	1Q
3 (34)	10 (50)	15 (48.3)	20 (54)	40 (52)	40 (41)	80	2	2	3GX2F0#*22K	SW-N2SRM/G2E	2F
5 (34)	15 (68)	20 (62.1)	25 (68)	50 (65)	50 (52)	100	2	2	3GX2H0#*22K	SW-N3RM/G2E	2H

If larger contactors or motor starters are required, please turn to page 27-30.

EXPLANATION OF PART NUMBER SYSTEM

3 G W 0 T 0 # * 2 2 K

● **PRODUCT LINE**
3=Odyssey Series

● **OPERATION**
G=DC Coil

● **DESCRIPTION**
C=Non-Reversing Contactor
D=Reversing Contactor
W=Non-Reversing Motor Starter
X=Reversing Motor Starter

● **FRAME SIZE**

● **FRAME ENCLOSURE**
0=Open Frame, No Enclosure

● **OVERLOAD TYPE**
K=Open Phase Protection
offered as a standard
(Motor Starters Only
Omit for Contactors)

● **QUANTITY OF N.C. AUX. CONTACTS**

● **QUANTITY OF N.O. AUX. CONTACTS**

● **OVERLOAD RANGE**
Select appropriate letter from chart
on page 31
(Motor Starters Only
Omit for Contactors)

● **COIL VOLTAGE**
Select code from chart on next page

"ODYSSEY SERIES" AC Contactors & Starters, DC Operated (Conventional DC Coils)

AVAILABLE COILS

Code Letter	DC Coil
T	12V
M	24V
N	48V
1	100V
R	110V
2	200V
S	220V

If AC operation is required,
please turn to page 23-24.

COIL CHARACTERISTICS

Frame Size	Power Consumption (VA)		Pick-up Voltage (V)	Drop-out Voltage (V)	Operating Time (ms)	
	Inrush	Sealed			Coil ON	Coil OFF
					Contact ON	Contact OFF
0T	9	9	10-14	4-8	40-48	17-21
1Q	9	9	10-14	4-8	40-48	17-21
2F	12	12	10-14	3-7	60-70	15-19
2H	12	12	10-14	3-7	60-70	15-19

This data is based on 24-26VDC coil, tested at 24VDC.
For additional coil data, please see page 52.

WIRING DIAGRAMS / AUXILIARY CONTACT INFORMATION

NON-REVERSING CONTACTORS

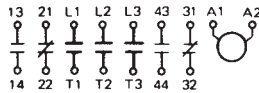

NON-REVERSING MOTOR STARTERS

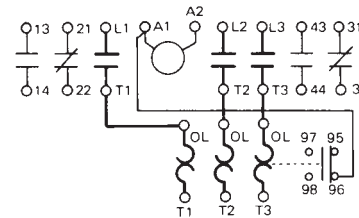

REVERSING CONTACTORS

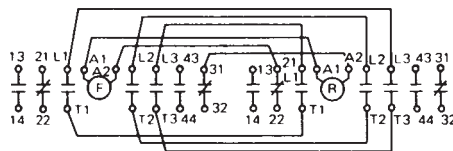

REVERSING MOTOR STARTERS

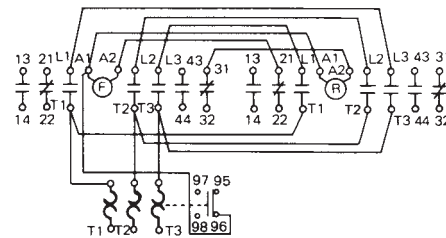

AUXILIARY CONTACT RATINGS

Operating	Contact rating Code Designation	Continuous Ampere Rating	Current-Make/Break (A)			
			110 to 120V	220 to 240V	440 to 480V	550 to 600V
AC	A600	10	60/6	30/3	15/1.5	12/1.2
DC	Q300	10	120V		240V	
			0.55/0.55	0.27/0.27		

Notes:

- All Odyssey series contactors and starters come equipped with 2NO + 2NC auxiliary contacts standard.
- Reversing contactors & starters from Frame size 0T through 2H can be constructed in the field. See Accessories on pages 33-34 for details. Large frame size reversing units only factory assembled.

"ODYSSEY SERIES" AC Contactors, Featuring Supermagnet Technology (AC or DC Operated)



■ NON-REVERSING CONTACTORS UL File No. E42419

1 Phase HP Rating (Full load ampere)		3 Phase HP Ratings (Full load ampere)				Rated thermal current for non inductive / resistive load	Qty. of Aux. Contacts		Part Number	Fuji Type	Frame Size
100-120V	220-240V	200-208V	220-240V	440-480V	550-600V		NO	NC			
2 (24)	5 (28)	71/2 (25.3)	10 (28)	25 (34)	25 (27)	50	2	2	3NC0T0#22/SE	SC-N1/SE	0T
3 (34)	71/2 (40)	10 (32.2)	15 (42)	30 (40)	30 (32)	60	2	2	3NC1Q0#22/SE	SC-N2/SE	1Q
3 (34)	10 (50)	15 (48.3)	20 (54)	40 (52)	40 (41)	80	2	2	3NC2F0#22/SE	SC-N2S/SE	2F
5 (34)	15 (68)	20 (62.1)	25 (68)	50 (65)	50 (52)	100	2	2	3NC2H0#22/SE	SC-N3/SE	2H
71/2 (56)	15 (68)	25 (78.2)	30 (80)	60 (77)	60 (62)	135	2	2	3NC2T0#22/SE	SC-N4/SE	2T
71/2 (56)	15 (68)	30 (92)	30 (80)	60 (77)	75 (77)	150	2	2	3NC3F0#22	SC-N5	3F
10	20	40 (119.6)	40 (104)	75 (96)	100 (99)	150	2	2	3NC3H0#22	SC-N6	3H
15	25	50 (149.5)	50 (130)	100 (124)	125 (125)	200	2	2	3NC4F0#22	SC-N7	4F
-	-	60 (177.1)	60 (154)	150 (180)	150 (144)	260	2	2	3NC4Q0#22	SC-N8	4Q
-	-	75 (220.8)	75 (192)	150 (180)	200 (192)	260	2	2	3NC4H0#22	SC-N10	4H
-	-	100 (285.2)	100 (248)	200 (240)	250 (242)	350	2	2	3NC5F0#22	SC-N11	5F
-	-	125 (358.6)	150 (360)	300 (361)	350 (336)	450	2	2	3NC5H0#22	SC-N12	5H
-	-	200 (552)	200 (480)	500 (590)	600 (578)	660	2	2	3NC6F0#22	SC-N14	6F
-	-	250 (692.3)	300 (720)	600 (722)	700 (672)	800	2	2	3NC6H0#22	SC-N16	6H

6F & 6H frame are only offered as contactor.

■ REVERSING CONTACTORS UL File No. E42419, cUL listed

1 Phase HP Rating (Full load ampere)		3 Phase HP Ratings (Full load ampere)				Rated thermal current for non inductive / resistive load	Qty. of Aux. Contacts		Part Number	Fuji Type	Frame Size
100-120V	220-240V	200-208V	220-240V	440-480V	550-600V		NO	NC			
2 (24)	5 (28)	71/2 (25.3)	10 (28)	25 (34)	25 (27)	50	2	2	3ND0T0#22/SE	SC-N1RM/SE	0T
3 (34)	71/2 (40)	10 (32.2)	15 (42)	30 (40)	30 (32)	60	2	2	3ND1Q0#22/SE	SC-N2RM/SE	1Q
3 (34)	10 (50)	15 (48.3)	20 (54)	40 (52)	40 (41)	80	2	2	3ND2F0#22/SE	SC-N2SRM/SE	2F
5 (34)	15 (68)	20 (62.1)	25 (68)	50 (65)	50 (52)	100	2	2	3ND2H0#22/SE	SC-N3RM/SE	2H
71/2 (56)	15 (68)	25 (78.2)	30 (80)	60 (77)	60 (62)	135	2	2	3ND2T0#22/SE	SC-N4RM/SE	2T
71/2 (56)	15 (68)	30 (92)	30 (80)	60 (77)	75 (77)	150	2	2	3ND3F0#22	SC-N5RM	3F
10	20	40 (119.6)	40 (104)	75 (96)	100 (99)	150	2	2	3ND3H0#22	SC-N6RM	3H
15	25	50 (149.5)	50 (130)	100 (124)	125 (125)	200	2	2	3ND4F0#22	SC-N7RM	4F
-	-	60 (177.1)	60 (154)	150 (180)	150 (144)	260	2	2	3ND4Q0#22	SC-N8RM	4Q
-	-	75 (220.8)	75 (192)	150 (180)	200 (192)	260	2	2	3ND4H0#22	SC-N10RM	4H
-	-	100 (285.2)	100 (248)	200 (240)	250 (242)	350	2	2	3ND5F0#22	SC-N11RM	5F
-	-	125 (358.6)	150 (360)	300 (361)	350 (336)	450	2	2	3ND5H0#22	SC-N12RM	5H
-	-	200 (552)	200 (480)	500 (590)	600 (578)	660	2	2	3ND6F0#22	SC-N14RM	6F
-	-	250 (692.3)	300 (720)	600 (722)	700 (672)	800	2	2	3ND6H0#22	SC-N16RM	6H

EXPLANATION OF PART NUMBER SYSTEM

3 N C 0 T 0 # 2 2 / S E

• **PRODUCT LINE**
3=Odyssey Series

• **OPERATION**
N=AC or DC Coil
(Super Magnet)

• **DESCRIPTION**
C=Non-Reversing Contactor
D=Reversing Contactor

• **FRAME SIZE**

• **FRAME ENCLOSURE**
0=Open Frame, No Enclosure

• **SUPER MAGNET OPTION**
SE=Super Magnet Option "SE" is
an option on frames 0T, 1Q,
2F, 2H & 2T. All other frames
offer Super Magnet standard.

• **QUANTITY OF N.C. AUX. CONTACTS**

• **QUANTITY OF N.O. AUX. CONTACTS**

• **COIL VOLTAGE**
Select code from chart on next page

"ODYSSEY SERIES" AC Contactors, Featuring Supermagnet Technology (AC or DC Operated)

AVAILABLE COILS

Code Letter	AC 50/60Hz	DC
E	24-25V	24V
F	48-50V	48V
1	100-127V	100-120V
2	200-250V	200-240V
Q	380-450V	N/A
4	460-575V	N/A

Note: The coil is energized by either an AC or DC input. (Code letter: E, F, 1, 2)

COIL CHARACTERISTICS

Frame Size	Power Consumption (VA)		Pick-up Voltage (V)	Drop-out Voltage (V)	Operating Time (ms)	
	Inrush Sealed				Coil ON Contact ON	Coil OFF Contact OFF
0T/SE, 1Q/SE	137	3.9	70-80	35-50	20-25	20-25
2F/SE, 2H/SE	168	3.8	70-80	35-50	23-28	24-29
2T/SE	130	3.9	70-80	35-50	32-36	30-33
3F	130	3.9	70-80	35-50	32-36	30-33
3H	210	4.4	70-80	35-50	32-36	30-33
4F	210	4.4	70-80	35-50	32-36	30-33
4Q, 4H	277	5.4	70-80	35-50	35-41	37-45
5F, 5H	265	5.9	70-80	35-50	40-47	36-43

This data is based on 100-120V SUPERMAGNET coil, tested at 120VAC, 60Hz. For additional coil data, please see page 51-52.

0T/SE, 1Q/SE	155	2.6	77-88	28-44	20-25	20-25
2F/SE, 2H/SE	195	2.5	77-88	28-44	23-28	24-29
2T/SE	112	2.6	77-88	28-44	32-36	30-33
3F	112	2.6	77-88	28-44	32-36	30-33
3H	255	3	77-88	28-44	32-36	30-33
4F	255	3	77-88	28-44	32-36	30-33
4Q, 4H	324	4.1	77-88	28-44	35-41	37-45
5F, 5H	340	4.5	77-88	28-44	40-47	36-43

This data is based on 100-120V SUPERMAGNET coil, tested at 110VDC. For additional coil data, please see page 51-52.

WIRING DIAGRAMS / AUXILIARY CONTACT INFORMATION

NON-REVERSING CONTACTORS



REVERSING CONTACTORS

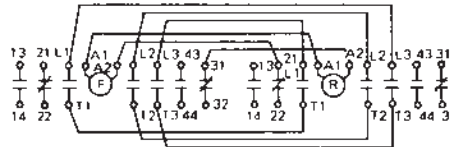

Notes:

- All Odyssey series contactors and starters come equipped with 2NO + 2NC auxiliary contacts standard.
- Reversing contactors & starters from Frame size 0T through 2H can be constructed in the field. See Accessories on pages 33-34 for details. Large frame size reversing units only factory assembled.

AUXILIARY CONTACT RATINGS

Operating	Contact rating Code Designation	Continuous Ampere Rating	Current-Make/Break (A)			
			110 to 120V	220 to 240V	440 to 480V	550 to 600V
AC	A600	10	60/6	30/3	15/1.5	12/1.2
DC	Q300	10	120V		240V	
			0.55/0.55		0.27/0.27	

"ODYSSEY SERIES" AC Motor Starters, Featuring Supermagnet Technology (AC or DC Operated)



■ NON-REVERSING MOTOR STARTERS UL File No. E42419, cUL listed

1 Phase HP Rating (Full load ampere)		3 Phase HP Ratings (Full load ampere)				Rated thermal current for non inductive / resistive load	Qty. of Aux. Contacts		Part Number	Fuji Type	Frame Size
100-120V	220-240V	200-208V	220-240V	440-480V	550-600V		NO	NC			
2(24)	5 (28)	71/2 (25.3)	10 (28)	25 (34)	25 (27)	50	2	2	3NW0T0#*22K/SE	SW-N1/SE2E	0T
3(34)	7 1/2 (40)	10 (32.2)	15 (42)	30 (40)	30 (32)	60	2	2	3NW1Q0#*22K/SE	SW-N2/SE2E	1Q
3(34)	10 (50)	15 (48.3)	20 (54)	40 (52)	40 (41)	80	2	2	3NW2F0#*22K/SE	SW-N2S/SE2E	2F
5(34)	15 (68)	20 (62.1)	25 (68)	50 (65)	50 (52)	100	2	2	3NW2H0#*22K/SE	SW-N3/SE2E	2H
7 1/2(56)	15 (68)	25 (78.2)	30 (80)	60 (77)	60 (62)	135	2	2	3NW2T0#*22K/SE	SW-N4/SE2E	2T
7 1/2(56)	15 (68)	30 (92)	30 (80)	60 (77)	75 (77)	150	2	2	3NW3F0#*22K	SW-N5/2E	3F
10	20	40 (119.6)	40 (104)	75 (96)	100 (99)	150	2	2	3NW3H0#*22K	SW-N6/2E	3H
15	25	50 (149.5)	50 (130)	100 (124)	125 (125)	200	2	2	3NW4F0#*22K	SW-N7/2E	4F
-	-	60 (177.1)	60 (154)	150 (180)	150 (144)	260	2	2	3NW4Q0#*22K	SW-N8/2E	4Q
-	-	75 (220.8)	75 (192)	150 (180)	200 (192)	260	2	2	3NW4H0#*22K	SW-N10/2E	4H
-	-	100 (285.2)	100 (248)	200 (240)	250 (242)	350	2	2	3NW5F0#*22K	SW-N11/2E	5F
-	-	125 (358.6)	150 (360)	300 (361)	350 (336)	450	2	2	3NW5H0#*22K	SW-N12/2E	5H

■ REVERSING MOTOR STARTERS UL File No. E42419, cUL listed

1 Phase HP Rating (Full load ampere)		3 Phase HP Ratings (Full load ampere)				Rated thermal current for non inductive / resistive load	Qty. of Aux. Contacts		Part Number	Fuji Type	Frame Size
100-120V	220-240V	200-208V	220-240V	440-480V	550-600V		NO	NC			
2 (24)	5 (28)	71/2 (25.3)	10 (28)	25 (34)	25 (27)	50	2	2	3NX0T0#*22K/SE	SW-N1RM/SE2E	0T
3 (34)	7 1/2 (40)	10 (32.2)	15 (42)	30 (40)	30 (32)	60	2	2	3NX1Q0#*22K/SE	SW-N2RM/SE2E	1Q
3 (34)	10 (50)	15 (48.3)	20 (54)	40 (52)	40 (41)	80	2	2	3NX2F0#*22K/SE	SW-N2SRM/SE2E	2F
5 (34)	15 (68)	20 (62.1)	25 (68)	50 (65)	50 (52)	100	2	2	3NX2H0#*22K/SE	SW-N3RM/SE2E	2H
7 1/2 (56)	15 (68)	25 (78.2)	30 (80)	60 (77)	60 (62)	135	2	2	3NX2T0#*22K/SE	SW-N4RM/SE2E	2T
7 1/2 (56)	15 (68)	30 (92)	30 (80)	60 (77)	75 (77)	150	2	2	3NX3F0#*22K	SW-N5RM/2E	3F
10	20	40 (119.6)	40 (104)	75 (96)	100 (99)	150	2	2	3NX3H0#*22K	SW-N6RM/2E	3H
15	25	50 (149.5)	50 (130)	100 (124)	125 (125)	200	2	2	3NX4F0#*22K	SW-N7RM/2E	4F
-	-	60 (177.1)	60 (154)	150 (180)	150 (144)	260	2	2	3NX4Q0#*22K	SW-N8RM/2E	4Q
-	-	75 (220.8)	75 (192)	150 (180)	200 (192)	260	2	2	3NX4H0#*22K	SW-N10RM/2E	4H
-	-	100 (285.2)	100 (248)	200 (240)	250 (242)	350	2	2	3NX5F0#*22K	SW-N11RM/2E	5F
-	-	125 (358.6)	150 (360)	300 (361)	350 (336)	450	2	2	3NX5H0#*22K	SW-N12RM/2E	5H

EXPLANATION OF PART NUMBER SYSTEM

3 N W 0 T 0 # * 2 2 K / S E

• **PRODUCT LINE**
3=Odyssey Series

• **OPERATION**
N=AC or DC Coil
(Super Magnet)

• **DESCRIPTION**
W=Non-Reversing Motor Starter
X=Reversing Motor Starter

• **FRAME SIZE**

• **FRAME ENCLOSURE**
0=Open Frame, No Enclosure

• **SUPER MAGNET OPTION**
SE=Super Magnet Option
"SE" is an option on
frames 0T, 1Q, 2F, 2H & 2T.
All other frames offer
Super Magnet standard.

• **OVERLOAD TYPE**
K=Open Phase Protection
offered as a standard

• **QUANTITY OF N.C. AUX. CONTACTS**

• **QUANTITY OF N.O. AUX. CONTACTS**

• **OVERLOAD RANGE**
Select appropriate letter from chart on page 31

• **COIL VOLTAGE**
Select code from chart on next page

"ODYSSEY SERIES" AC Motor Starters, Featuring Supermagnet Technology (AC or DC Operated)

AVAILABLE COILS

Code Letter	AC 50/60Hz	DC
E	24-25V	24V
F	48-50V	48V
1	100-127V	100-120V
2	200-250V	200-240V
Q	380-450V	N/A
4	460-575V	N/A

Note: The coil is energized by either an AC or DC input. (Code letter: E, F, 1, 2)

COIL CHARACTERISTICS

Frame Size	Power Consumption (VA)		Pick-up Voltage (V)	Drop-out Voltage (V)	Operating Time (ms)	
	Inrush Sealed				Coil ON ↓ Contact ON	Coil OFF ↓ Contact OFF
0T/SE, 1Q/SE	137	3.9	70-80	35-50	20-25	20-25
2F/SE, 2H/SE	168	3.8	70-80	35-50	23-28	24-29
2T/SE	130	3.9	70-80	35-50	32-36	30-33
3F	130	3.9	70-80	35-50	32-36	30-33
3H	210	4.4	70-80	35-50	32-36	30-33
4F	210	4.4	70-80	35-50	32-36	30-33
4Q, 4H	277	5.4	70-80	35-50	35-41	37-45
5F, 5H	265	5.9	70-80	35-50	40-47	36-43

This data is based on 100-120V SUPERMAGNET coil, tested at 120VAC, 60Hz. For additional coil data, please see page 51-52.

0T/SE, 1Q/SE	155	2.6	77-88	28-44	20-25	20-25
2F/SE, 2H/SE	195	2.5	77-88	28-44	23-28	24-29
2T/SE	112	2.6	77-88	28-44	32-36	30-33
3F	112	2.6	77-88	28-44	32-36	30-33
3H	255	3	77-88	28-44	32-36	30-33
4F	255	3	77-88	28-44	32-36	30-33
4Q, 4H	324	4.1	77-88	28-44	35-41	37-45
5F, 5H	340	4.5	77-88	28-44	40-47	36-43

This data is based on 100-120V SUPERMAGNET coil, tested at 110VDC. For additional coil data, please see page 51-52.

WIRING DIAGRAMS / AUXILIARY CONTACT INFORMATION

NON-REVERSING MOTOR STARTERS

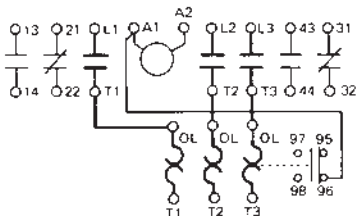

REVERSING MOTOR STARTERS

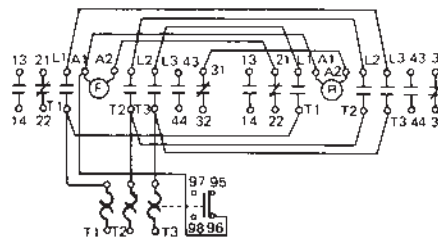

AUXILIARY CONTACT RATINGS

Operating	Contact Rating Code Designation	Continuous Ampere Rating	Current-Make/Break (A)			
			110 to 120V	220 to 240V	440 to 480V	550 to 600V
AC	A600	10	60/6	30/3	15/1.5	12/1.2
DC	Q300	10	120V		240V	
			0.55/0.55		0.27/0.27	

Notes:

- 1) All Odyssey series contactors and starters come equipped with 2NO + 2NC auxiliary contacts standard.
- 2) Reversing contactors & starters from Frame size 0T through 2H can be constructed in the field. See Accessories on pages 33-34 for details. Large frame size reversing units only factory assembled.

"ODYSSEY SERIES" THERMAL OVERLOAD RELAYS

OVERLOAD PART # [JAPANESE TYPE #]		3NK1Q* [TK-N2]		3NK2H* [TK-N3]		3NK3F* [TK-N5]	
CONTACTOR USED ON		3NC0T... [SC-N1]	3NC1Q... [SC-N2]	3NC2F... [SC-N2S]	3NC2H... [SC-N3]	3NC2T... [SC-N4]	3NC3F... [SC-N5]
AMPERE RANGE CODE LETTER	N	4-6	4-6				
	P	5-8	5-8				
	Q	6-9	6-9				
	S	7-11	7-11	7-11	7-11		
	T	9-13	9-13	9-13	9-13		
	V	12-18	12-18	12-18	12-18		
	W	18-26	18-26	18-26	18-26	18-26	18-26
	Y	24-36	24-36	24-36	24-36	24-36	24-36
	Z			28-40	28-40	28-40	28-40
	A		32-42				
	E			34-50	34-50	34-50	34-50
	F			45-65	45-65	45-65	45-65
	G				48-68		
	H					53-80	53-80
K						65-95	
M						85-105	

OVERLOAD PART # [JAPANESE TYPE #]		3NK3H* [TK-N6]	3NK4F* [TK-N7]	3NK4Q* [TK-N8]	3NK4H* [TK-N10]	3NK5H* [TK-N12]	
CONTACTOR USED ON		3NC3H... [SC-N6]	3NC4F... [SC-N7]	3NC4Q... [SC-N8]	3NC4H... [SC-N10]	3NC5F... [SC-N11]	3NC5H... [SC-N12]
AMPERE RANGE CODE LETTER	F	45-65	45-65				
	H	53-80	53-80				
	K	65-95	65-95	65-95			
	L	85-125	85-125	85-125	85-125		
	N		110-160	110-160	110-160	110-160	110-160
	P			125-185	125-185	125-185	125-185
	Q				160-240	160-240	160-240
	R					200-300	200-300
	T						240-360
							300-450

EXPLANATION OF PART NUMBER SYSTEM

3 N K 3 H *

• **PRODUCT LINE**
3N=Odyssey Series

• **STYLE**
K=Open Phase Protection
(offered as a standard feature)

• **AMPERE RANGE CODE**
See above chart

• **FRAME SIZE**
1Q-5H

"ODYSSEY SERIES" THERMAL OVERLOAD RELAYS

Overload Trip Curves

■ THERMAL OVERLOAD RELAYS/OPEN-PHASE PROTECTION TYPE K

3NK1Q* - 3NK4Q*

Cold start

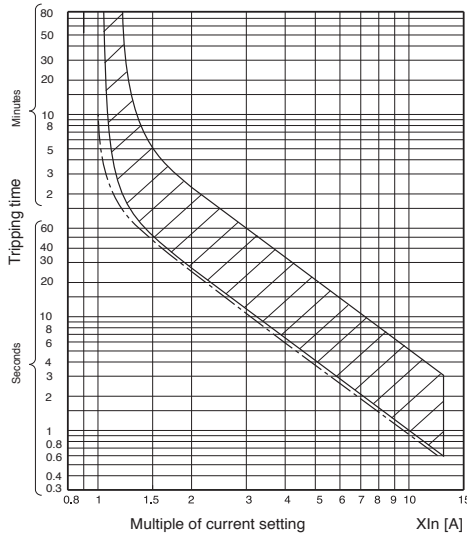

Hot start

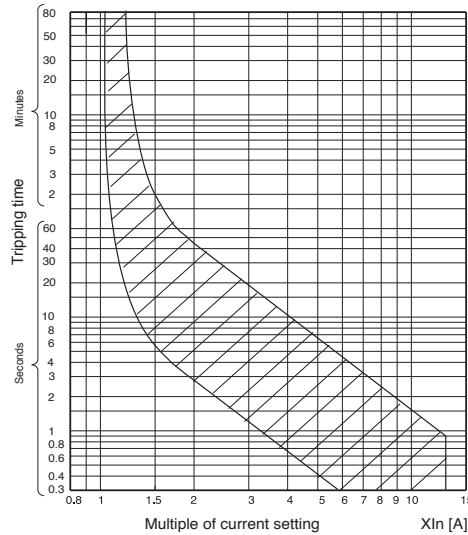

3NK4H* - 3NK5H*

Cold start

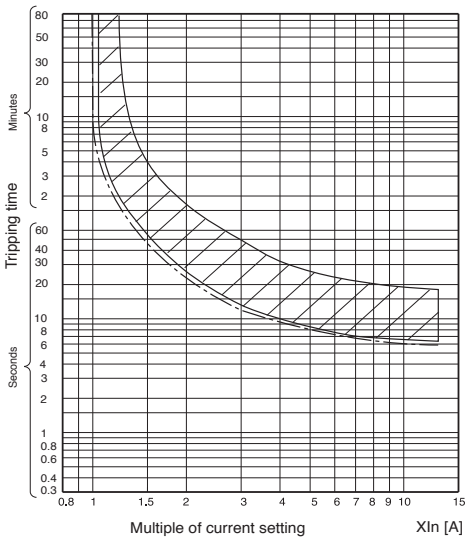

Hot start

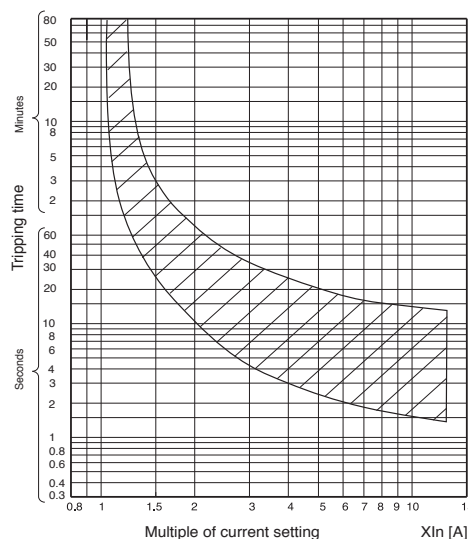

■ AMBIENT TEMPERATURE COMPENSATOR

FUJI overload relays are provided with an ambient temperature compensator. Their characteristics limit ampere value changes to approx. 10% as the ambient temperature changes between -5°C and 40°C.

Compensation characteristics (Average value)

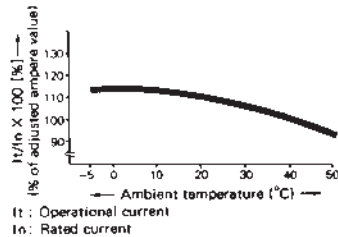

■ WIRING DIAGRAMS

(3NK1Q* through 3NK4Q*)

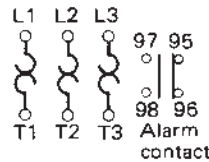

(3NK4H* through 3NK5H*)

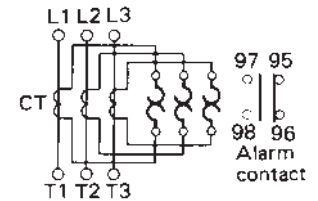

■ ALARM CONTACT RATINGS

Contact rating Code Designation	Continuous Ampere Rating	Current-Make/Break (A)			
		110 to 120V	220 to 240V	440 to 480V	550 to 600V
C600	2.5	15/1.5	7.5/0.75	3.75/0.375	3.0/0.3

SZ-HD
SZ-HE

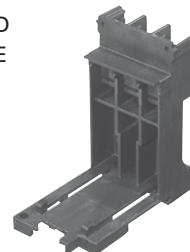

Base unit for separate mounting

"ODYSSEY SERIES" ACCESSORIES, Frames 0T-2H

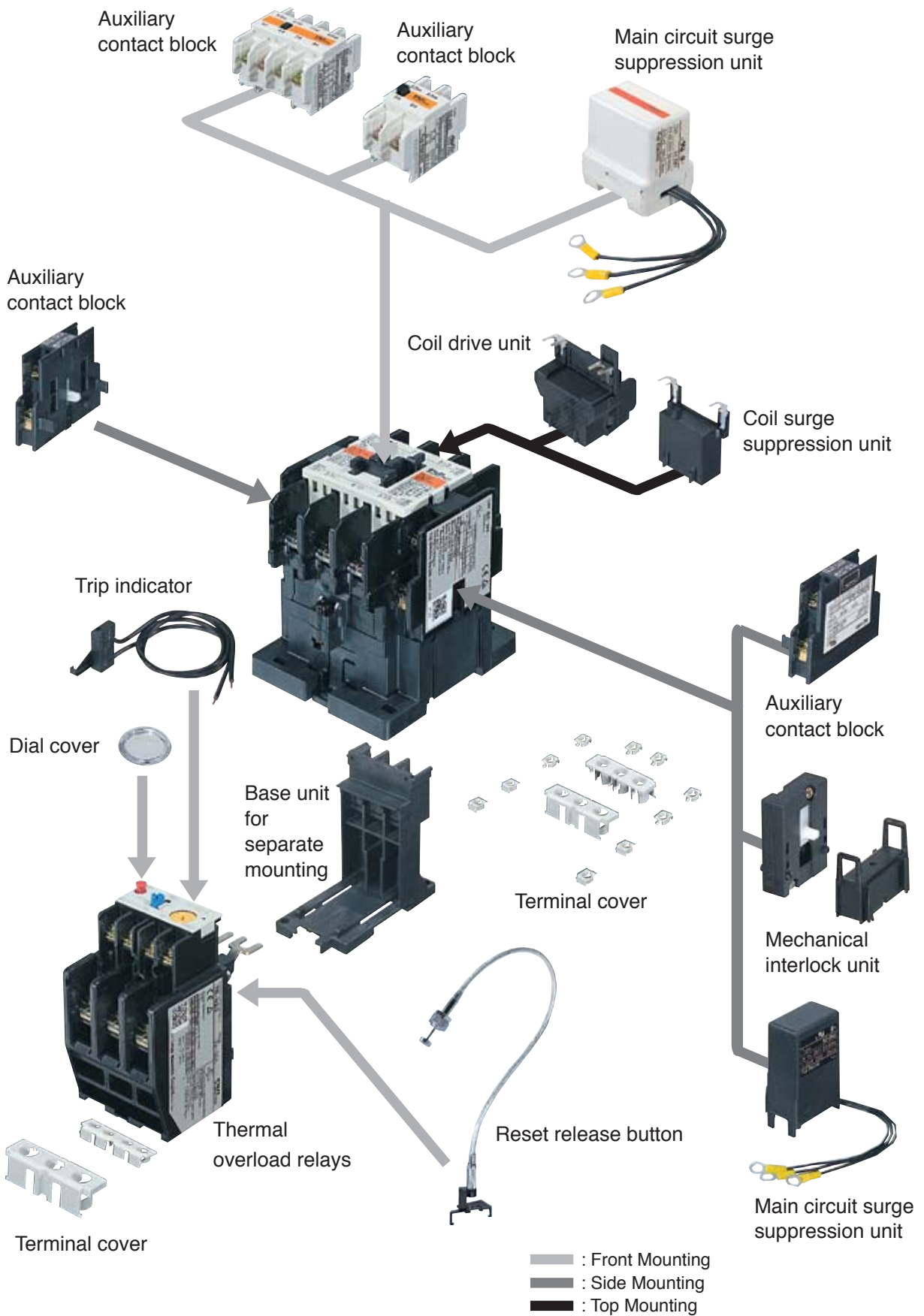

"ODYSSEY SERIES" ACCESSORIES, Frames 0T-2H

Description	Type	
Auxiliary Contact Block	• Front mounting	
	4NO	SZ-A40
	3NO+1NC	SZ-A31
	2NO+2NC	SZ-A22
	2NO	SZ-A20
	1NO+1NC	SZ-A11
	2NC	SZ-A02
	1NO+1NC (Over lapping)	SZ-A111
	2NO+2NC (Over lapping)	SZ-A222
	• Side mounting	SZ-AS1
	1NO+1NC (Ambidextrous)	

Front mounting type and side mounting type auxiliary contact blocks cannot be used simultaneously.

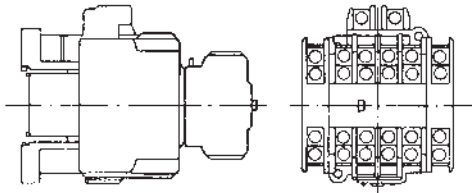

Operating Counter	Without alarm contact	SZ-J
3-pole Parallel Connection Link	For 3NC0T0, 3NC1Q0 (2 pcs.)	SZ-SP3
	For 3NC2F0, 3NC2H0 (2 pcs.)	SZ-SP4
Coil Drive Unit	DC24V relay output	SZ-CD3
	DC24V SSR output	SZ-CD4
Mechanical Interlock Unit	For 3NC0T0-3NC2H0	SZ-RM
Power Connection Kit for Reversing	For 3NC0T0, 3NC1Q0	SZ-RW5
	For 3NC2F0, 3NC2H0	SZ-RW6

Description	Type		
Terminal Cover	• Contactor For 0T0, 1Q0 For 2F0, 2H0	SZ-T22 SZ-T23	
	• Auxiliary contact block For 4-pole, front mounting For 2-pole, front mounting For 2-pole, side mounting	SZ-T5 SZ-T6 SZ-T7	
	• Thermal overload relay For 3NK1Q For 3NK2H Base unit for separate mounting: For SZ-HD For SZ-HE	SZ-T16 SZ-T17 SZ-T14 SZ-T15	
	Live-section Cover	• Contactor For 0T0, 1Q0 For 3NC2F0, 3NC2H0	SZ-N1J SZ-N2SJ
		• Starter For 0T0, 1Q0 For 2F0, 2H0	SZ-WN1J SZ-WN2SJ
	Coil Surge Suppression Unit	Varistor: 24 to 48V AC/DC 100 to 250V AC/DC 380 to 440V AC	SZ-Z31 SZ-Z32 SZ-Z33
RC: 24 to 48V AC 100 to 250V AC 24 to 48V DC 100 to 250V DC		SZ-Z34 SZ-Z35 SZ-Z36 SZ-Z37	
Main Circuit Surge Suppression Unit		For 0T0, 1Q0 With delta-connected RC, 100 to 240V AC	
		• Front mounting • Side mounting	SZ-ZM3 SZ-ZM4
Base Unit for Separate Mounting		For 3NK1Q For 3NK2H	SZ-HD SZ-HE
Dial Cover	Used on all overloads	SZ-DA	
Trip Indicator	100 to 110V AC	SZ-L100N2	
	200 to 220V AC	SZ-L200N2	
Reset Release Button	Lead length: 300mm	SZ-R4	
	500mm	SZ-R5	
	700mm	SZ-R6	

All accessories can be field installed.

"ODYSSEY SERIES" ACCESSORIES, Frames 2T-5H

Description	Type	
Auxiliary Contact Block Side Mounting 1NO+1NC	SZ-AS2	
3-pole Parallel Connection Link	For 2T0, 3F0 (2 pcs.)	SZ-SP5
	For 3H0 (2 pcs.)	SZ-SP6
	For 4F0 (2 pcs.)	SZ-SP7
	For 4Q0, 3NC4H0 (2 pcs.)	SZ-SP8
	For 5F0, 5H0 (2 pcs.)	SZ-SP9
Coil Drive Unit	DC24V relay output	SZ-CD5
	DC24V SSR output	SZ-CD6

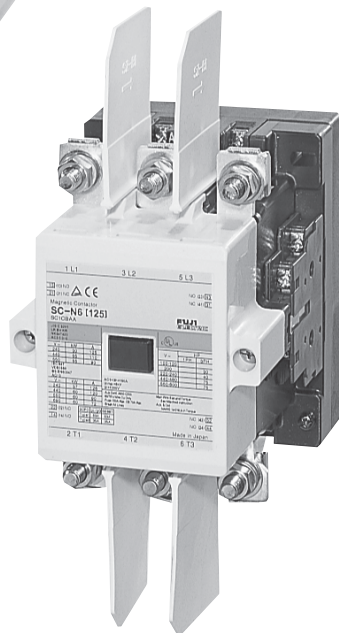
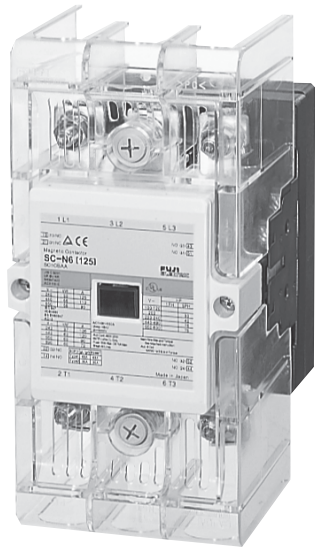

Description	Type	
Terminal Cover	<ul style="list-style-type: none"> Line & Load-side of Contactor Line-side of Starter 	SZ-N4T SZ-N6T SZ-N7T SZ-N8T SZ-N11T SZ-WN4T SZ-WN6T SZ-WN7T SZ-WN8T SZ-WN10T SZ-WN11T
	For 2T0, 3F0	
	For 3H0	
	For 4F0	
	For 4Q0, 4H0	
	For 5F0, 5H0	
	<ul style="list-style-type: none"> Load-side of Starter 	
	For 2T0, 3F0	
	For 3H0	
	For 4F0	
	For 4Q0	
For 4H0		
For 5F0, 5H0		
Live-section Cover	<ul style="list-style-type: none"> Contactor 	SZ-N4J SZ-N6J SZ-N7J SZ-N8J SZ-N11J SZ-WN4J SZ-WN6J SZ-WN7J SZ-WN8J SZ-WN10J SZ-WN11J
	For 2T0, 3F0	
	For 3H0	
	For 4F0	
	For 4Q0, 4H0	
	For 5F0, 5H0	
	<ul style="list-style-type: none"> Starter 	
	For 2T0, 3F0	
	For 3H0	
	For 4F0	
	For 4Q0	
For 4H0		
For 5F0, 5H0		
Insulation Barrier	For 2T0, 3F0, 3H0, 4F0, 3H, 4F	SZ-B1
	For 4Q0, 4H0, 5F0, 5H0, 3NK4Q, 3NK4H, 3NK5H	SZ-B2
Coil Surge Suppression Unit for 3NC2T0	Varistor: 24 to 48V AC/DC	SZ-Z41
	100 to 250V AC/DC	SZ-Z42
	380 to 440V AC	SZ-Z43
	RC: 24 to 48V AC	SZ-Z44
	100 to 250V AC	SZ-Z45
Dial Cover	Used on all overloads	SZ-DA
Trip Indicator	<ul style="list-style-type: none"> 3NK3F to 3NK4Q 	SZ-L100N2 SZ-L200N2
	100 to 110V AC	
	200 to 220V AC	
	<ul style="list-style-type: none"> 3NK4H, 3NK5H 	SZ-L200
200 to 220V AC		
Reset Release Button	<ul style="list-style-type: none"> 3NK3F to 3NK4Q 	SZ-R4 SZ-R5 SZ-R6
	Lead length: 300mm	
	500mm	
	700mm	
	<ul style="list-style-type: none"> 3NK4H, 3NK5H 	SZ-R1 SZ-R2 SZ-R3
	Lead length: 300mm	
500mm		
700mm		

"ODYSSEY SERIES" Replacement Parts

■ REPLACEMENT COILS

Frame Size	Conventional AC Coil Use codes from chart 1	Supermagnet Coil Use codes from chart 2
0T & 1Q	SZ-GM/N1-#	SZ-GS/N1-#
2F & 2H	SZ-GM/N2S-#	SZ-GS/N2S-#
2T	SZ-GM/N4-#	SZ-GS/N5-#
3F	N/A	SZ-GS/N5-#
3H & 4F	N/A	SZ-GS/N6-#
4Q & 4H	N/A	SZ-GS/N8-#
5F & 5H	N/A	SZ-GS/N11-#
6F & 6H	N/A	SZ-GS/N14-#

Replace the # symbol with the desired code, shown in the charts below.

COIL CHART #1

Code	AC 60Hz	AC 50Hz
24	24-26V	24V
48	48-52V	48V
100	100-110V	100V
110	110-120V	100-110V
120	120-130V	110-120V
200	200-220V	200V
220	220-240V	200-220V
400	400-440V	380-400V
440	440-480V	415-440V
550	550-600V	500-550V

COIL CHART #2

Code	AC 50/60Hz	DC
24	24-25V	24V
48	48-50V	48V
100	100-127V	100-120V
200	200-250V	200-240V
400	380-450V	N/A
500	460-575V	N/A

■ BOX LUGS

Frame Size	Contactors Line or Load Side	Moto. Starters	
		Line Side	Load Side
0T	NONE	NONE	NONE
1Q	NONE	NONE	NONE
2F & 2H	SZ-TL1	SZ-TL1	SZ-TL11
2T & 3F	SZ-TL2	SZ-TL2	SZ-TL11
3H	SZ-TL3	SZ-TL3	SZ-TL12
4F	SZ-TL4	SZ-TL4	SZ-TL12
4Q & 4H	SZ-TL5	SZ-TL5	SZ-TL5
5F	SZ-TL6	SZ-TL6	SZ-TL6
5H	SZ-TL7	SZ-TL7	SZ-TL7

■ REPLACEMENT CONTACTS

Frame Size	Contact Kit
0T	SZ-MC/SC-N1
1Q	SZ-MC/SC-N2
2F	SZ-MC/SC-N2S
2H	SZ-MC/SC-N3
2T	SZ-MC/SC-N4
3F	SZ-MC/SC-N5
3H	SZ-MC/SC-N6
4F	SZ-MC/SC-N7
4Q	SZ-MC/SC-N8
4H	SZ-MC/SC-N10
5F	SZ-MC/SC-N11
5H	SZ-MC/SC-N12
6F	SZ-MC/SC-N14
6H	SZ-MC/SC-N16

Note: 1) 3 movable and 6 stationary contacts included in each contact kit.
2) Contact kits consist of main contacts only. Auxiliary contacts are not included.

"ODYSSEY SERIES" Dimensions

CONTACTORS/OOPEN TYPE Approximate Dimensions, mm

3NC0T0#22
3NC1Q0#22

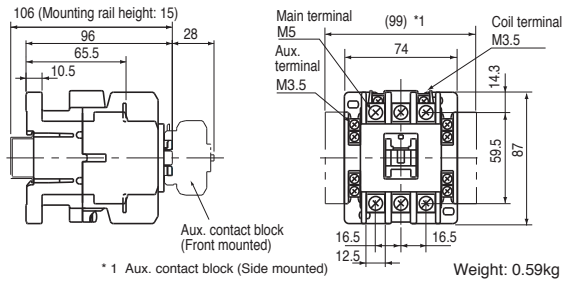

3NC2F0#22
3NC2H0#22

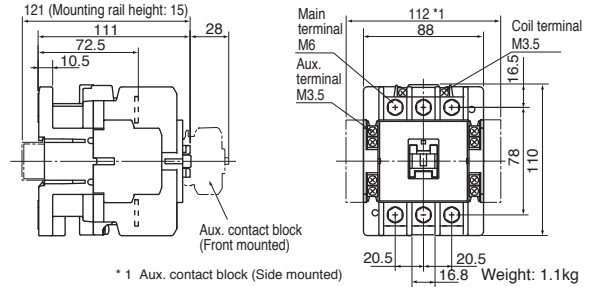

3NC2T0#22

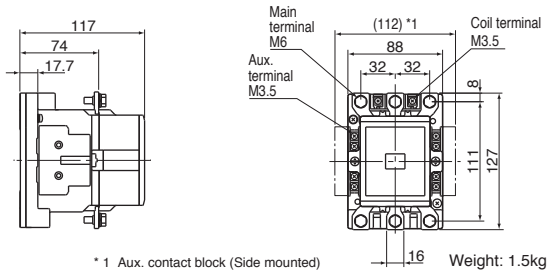

3NC3F0#22

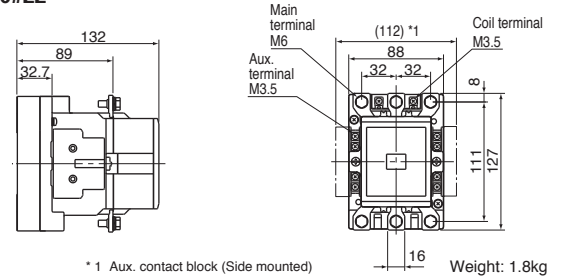

3NC3H0#22

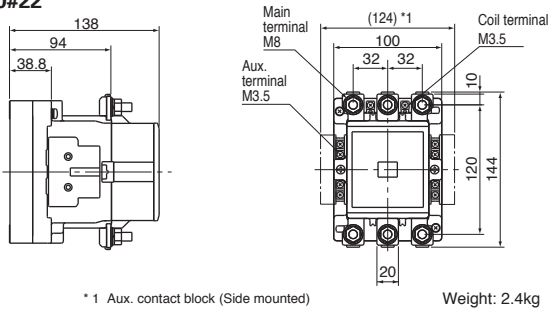

3NC4F0#22

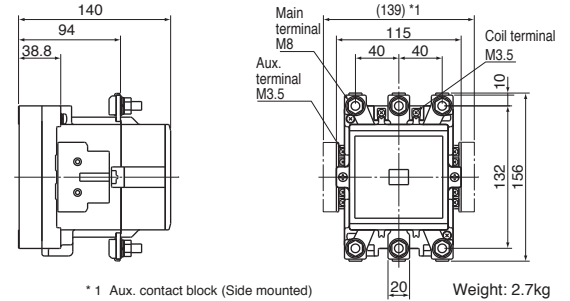

3NC4Q0#22
3NC4H0#22

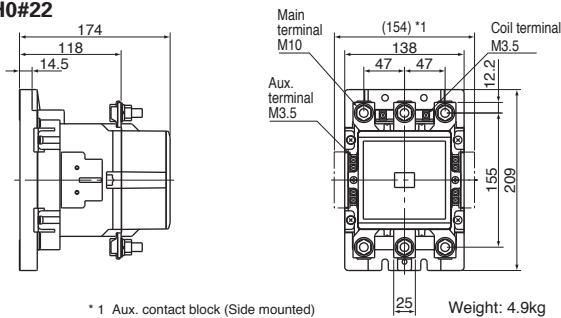

3NC5F0#22
3NC5H0#22

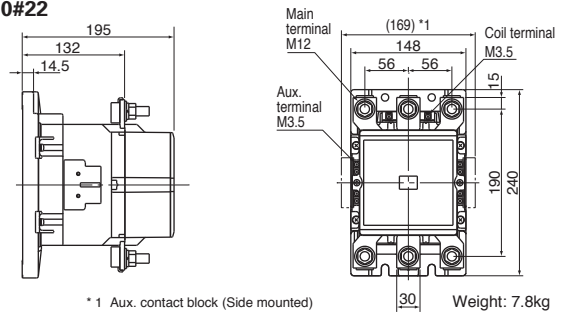

3NC6F0#22
3NC6H0#22

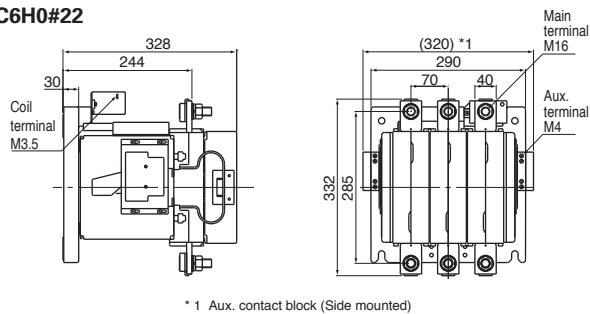

For exact mounting hole locations, please refer to the chart on page 48.

"ODYSSEY SERIES" Dimensions

STARTERS/OPEN TYPE Approximate Dimensions, mm

3NW0T0#*22K
3NW1Q0#*22K

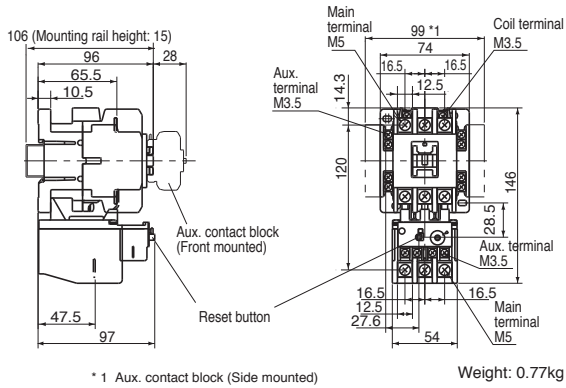

* 1 Aux. contact block (Side mounted) Weight: 0.77kg

3NW2F0#*22K
3NW2H0#*22K

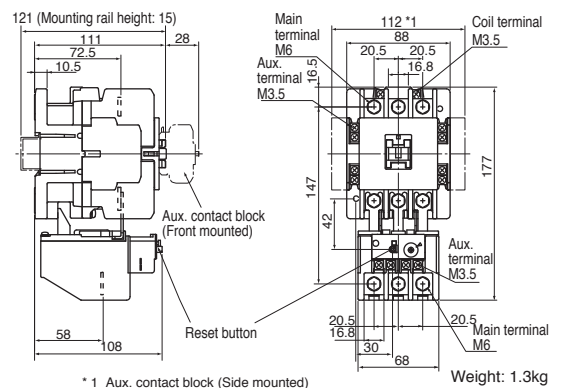

* 1 Aux. contact block (Side mounted) Weight: 1.3kg

3NW2T0#*22K

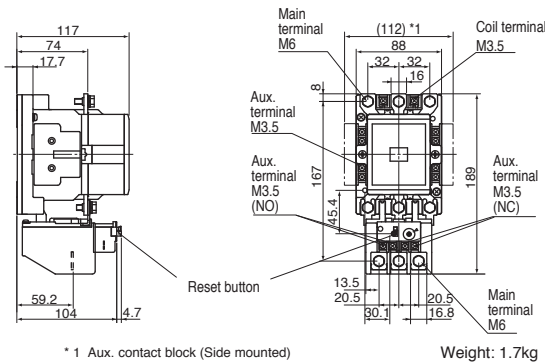

* 1 Aux. contact block (Side mounted) Weight: 1.7kg

3NW3F0#*22K

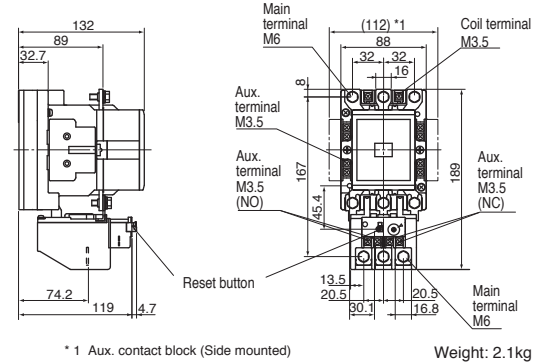

* 1 Aux. contact block (Side mounted) Weight: 2.1kg

3NW3H0#*22K

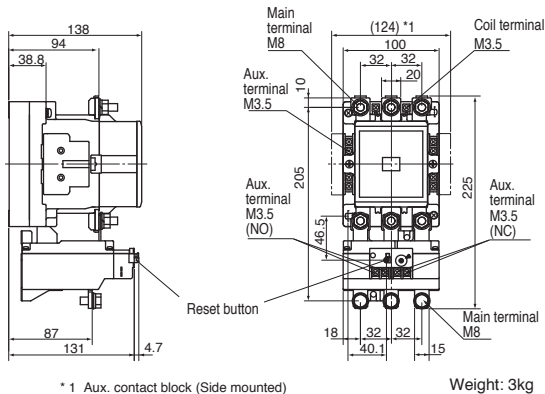

* 1 Aux. contact block (Side mounted) Weight: 3kg

3NW4F0#*22K

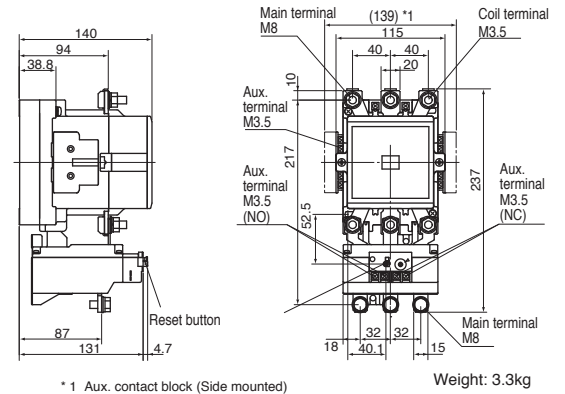

* 1 Aux. contact block (Side mounted) Weight: 3.3kg

3NW4Q0#*22K

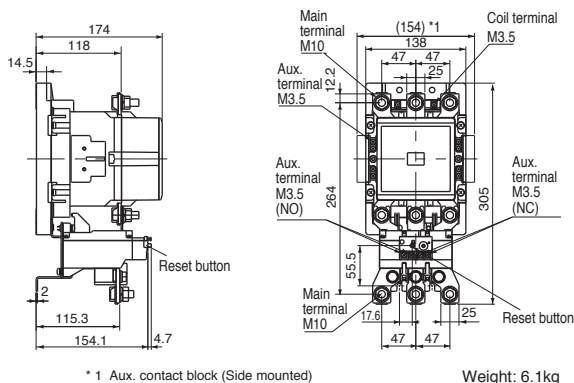

* 1 Aux. contact block (Side mounted) Weight: 6.1kg

3NW4H0#*22K

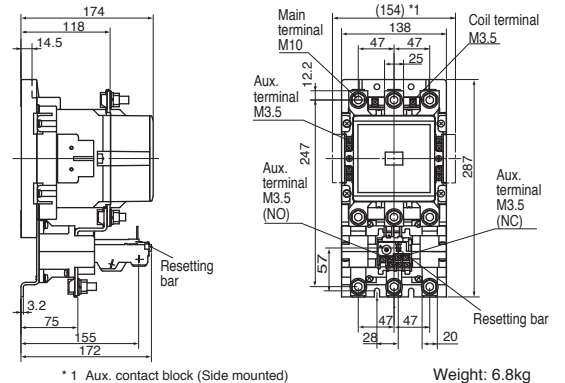

* 1 Aux. contact block (Side mounted) Weight: 6.8kg

For exact mounting hole locations, please refer to the chart on page 48.

"ODYSSEY SERIES" Dimensions

3NW5F0#*22K
3NW5H0#*22K

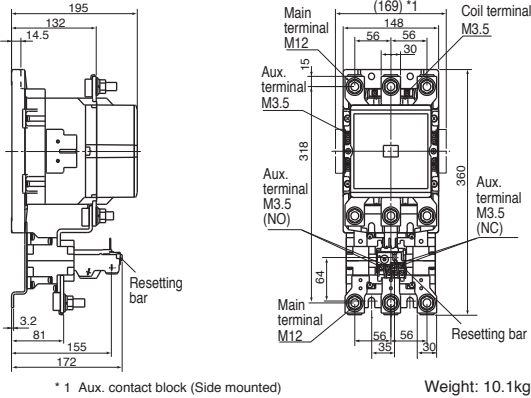

■ DC OPERATED CONTACTORS/OPEN TYPE Approximate Dimensions, mm

3GC0T0#22
3GC1Q0#22

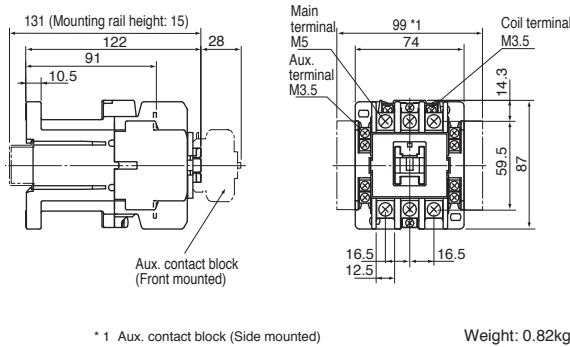

3GC2F0#22
3GC2H0#22

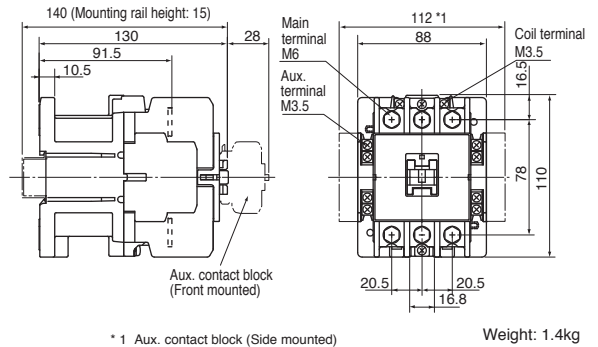

■ DC OPERATED STARTERS/OPEN TYPE Approximate Dimensions, mm

3GW0T0#*22K
3GW1Q0#*22K

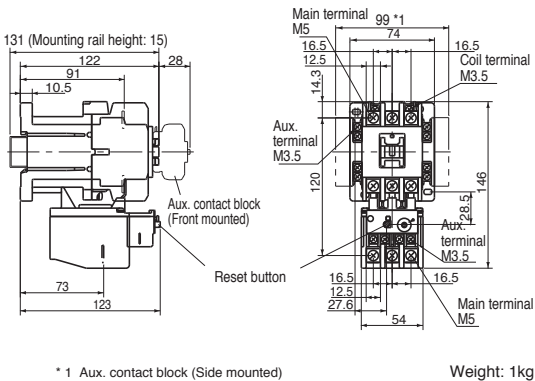

3GW2F0#*22K
3GW2H0#*22K

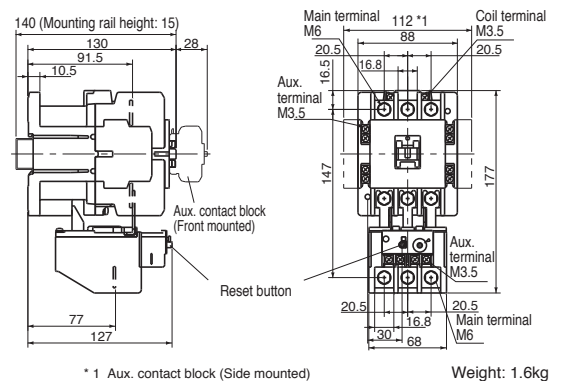

For exact mounting hole locations, please refer to the chart on page 48.

"ODYSSEY SERIES" Dimensions

CONTACTORS WITH "SUPER MAGNET" OPTION/OPEN TYPE Approximate Dimensions, mm

3NC0T0#22/SE
3NC1Q0#22/SE

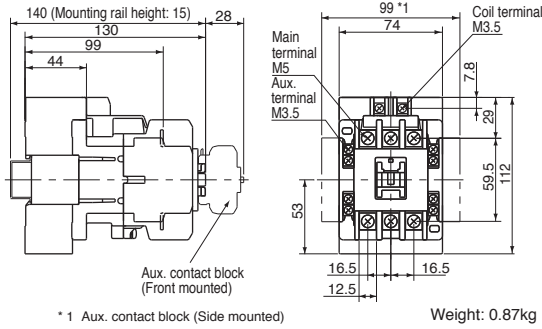

3NC2F0#22/SE
3NC2H0#22/SE

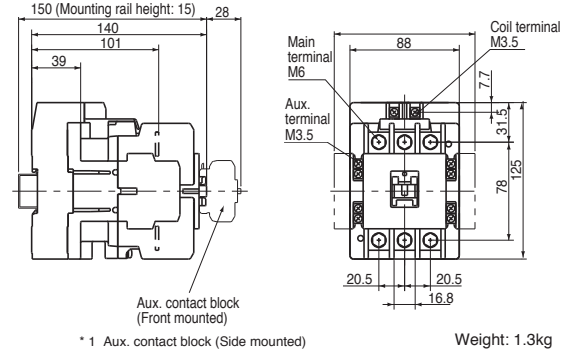

3C2T0#22/SE

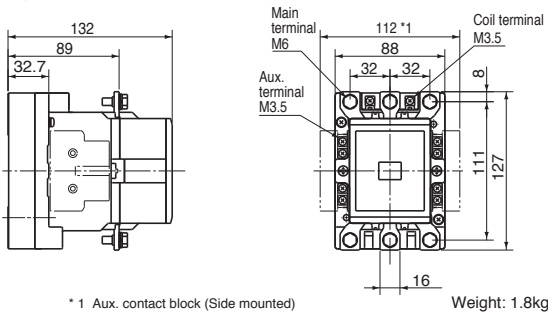

STARTERS WITH "SUPER MAGNET" OPTION/OPEN TYPE Approximate Dimensions, mm

3NW0T0#*22K/SE
3NW1Q0#*22K/SE

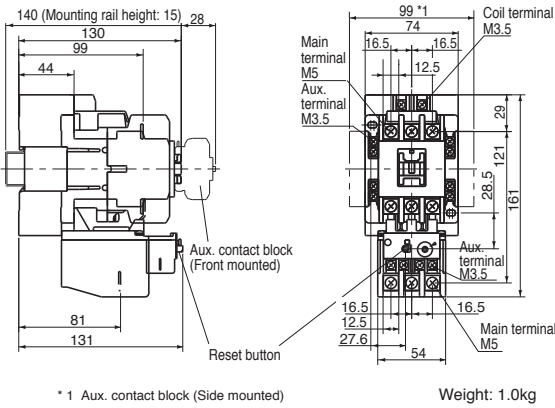

3NW2F0#*22K/SE
3NW2H0#*22K/SE

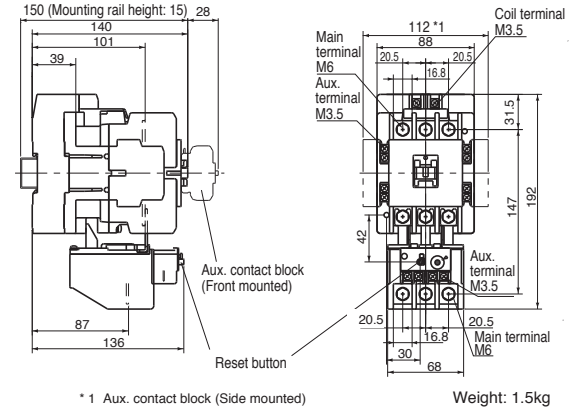

3NW2T0#*22K/SE

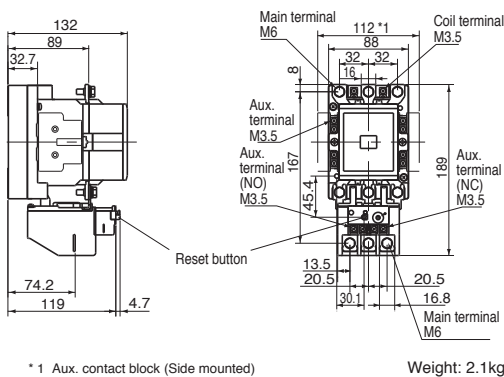

For exact mounting hole locations, please refer to the chart on page 48.

"ODYSSEY SERIES" Dimensions

REVERSING CONTACTORS/OPEN TYPE Approximate Dimensions, mm

3ND0T0#22
3ND1Q0#22

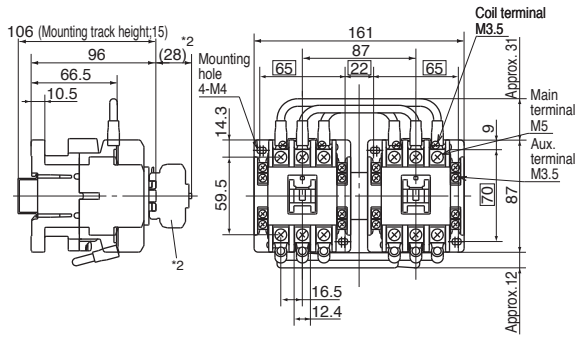

* 2 Aux. contact block. Front mounted (If Used)

3ND2F0#22
3ND2H0#22

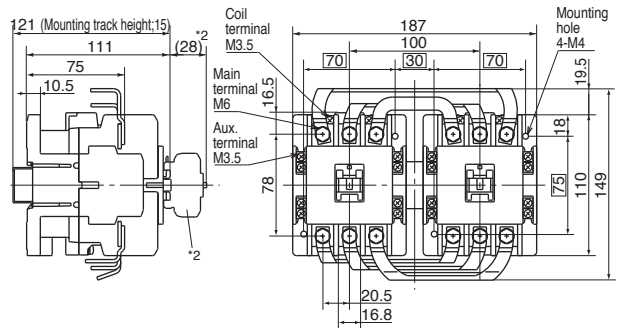

* 2 Aux. contact block. Front mounted (If Used)

3ND2T0#22

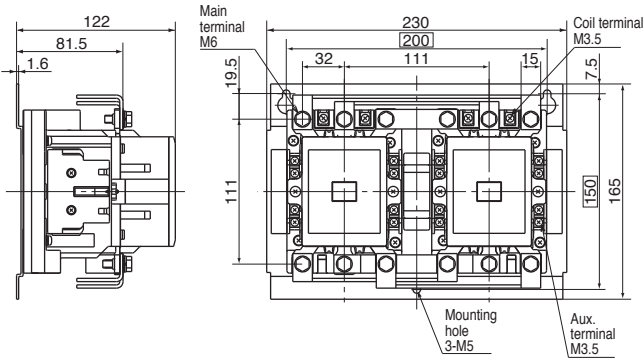

3ND3F0#22

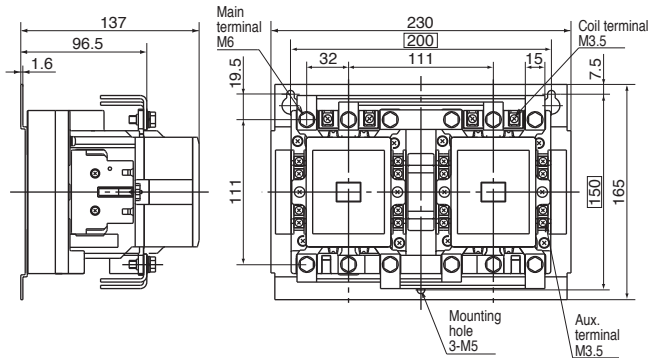

3ND3H0#22

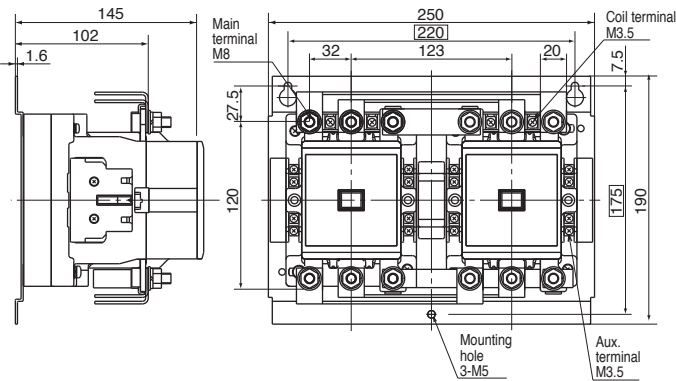

3ND4F0#22

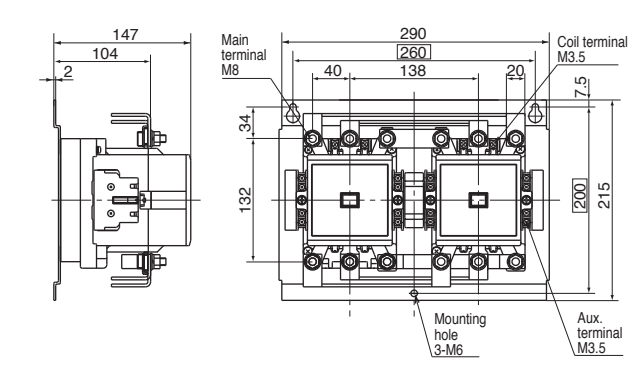

3ND4Q0#22
3ND4H0#22

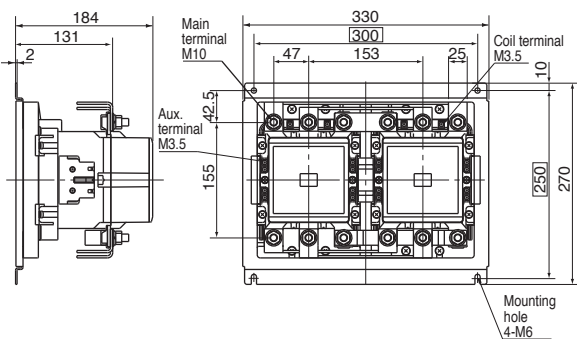

3ND5F0#22
3ND5H0#22

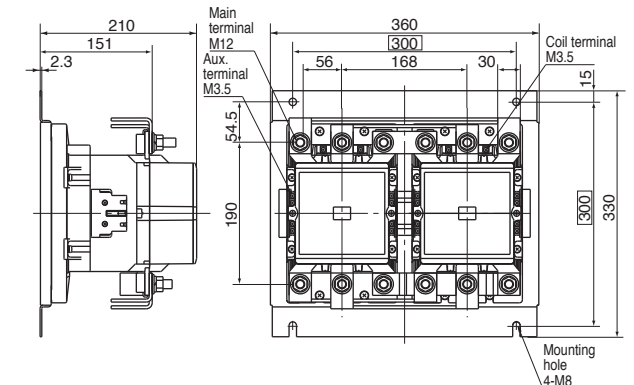

For exact mounting hole locations, please refer to the chart on page 48.

"ODYSSEY SERIES" Dimensions

3NX4Q0#*22K

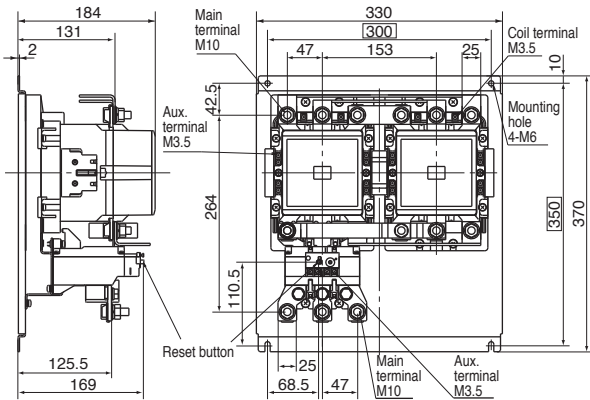

3NX4H0#*22K

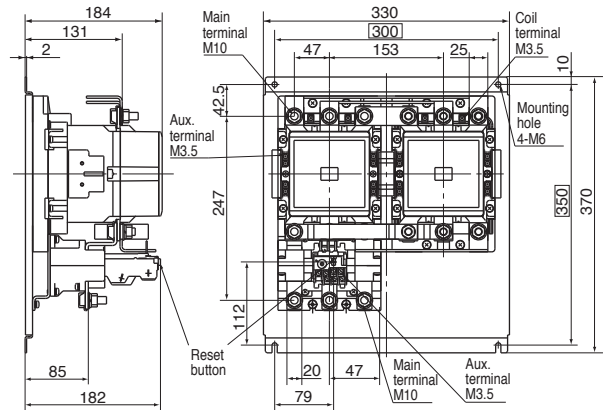

3NX5F0#*22K
3NX5H0#*22K

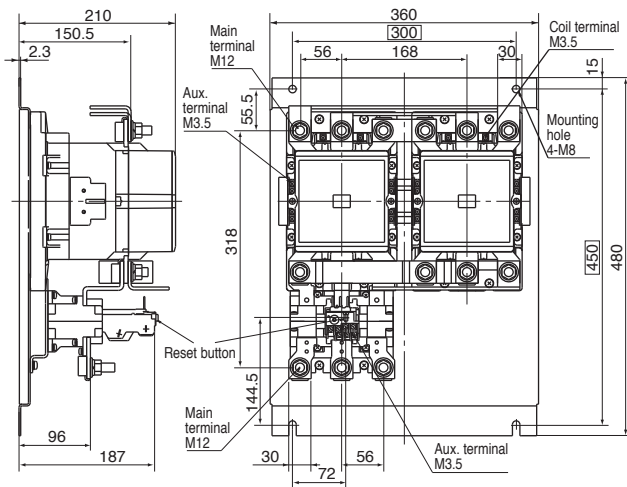

DC OPERATED REVERSING CONTACTORS/OPEN TYPE Approximate Dimensions, mm

3GD0T0#22
3GD1Q0#22

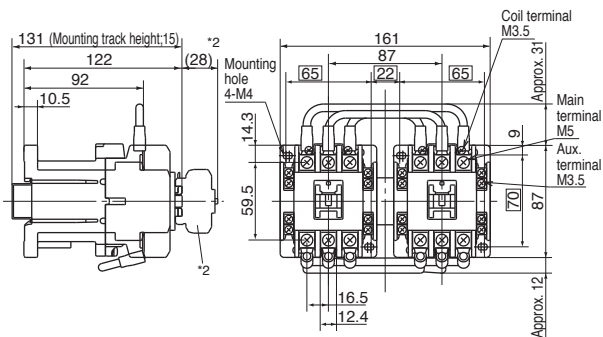

* 2 Aux. contact block. Front mounted (If Used)

3GD2F0#22
3GD2H0#22

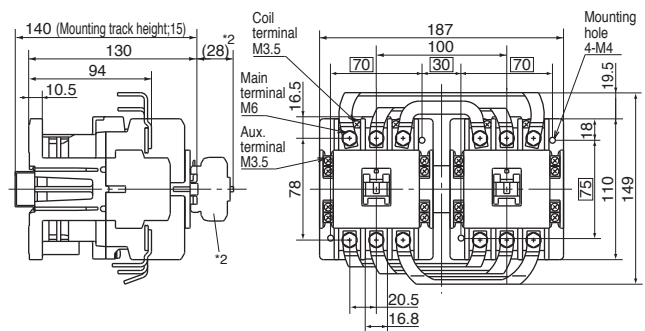

* 2 Aux. contact block. Front mounted (If Used)

For exact mounting hole locations, please refer to the chart on page 48.

"ODYSSEY SERIES" Dimensions

DC OPERATED REVERSING STARTERS/OPEN TYPE Approximate Dimensions, mm

3GX0T0#*22K
3GX1Q0#*22K

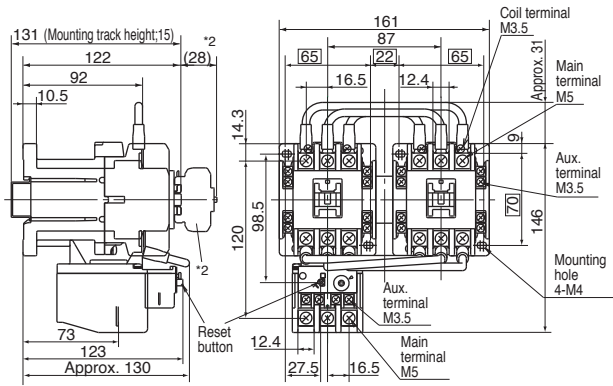

* 2 Aux. contact block. Front mounted (If Used)

3GX2F0#*22K
3GX2H0#*22K

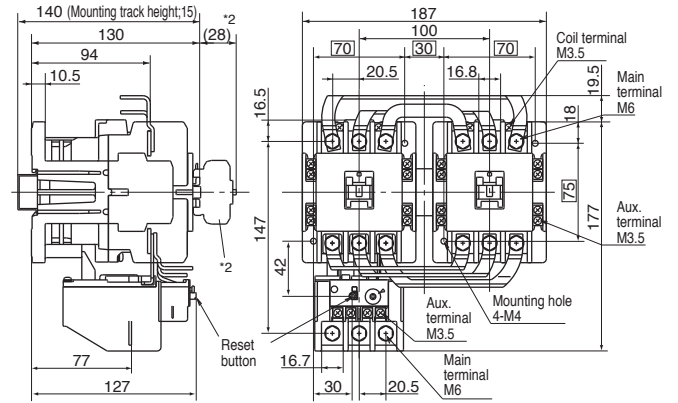

* 2 Aux. contact block. Front mounted (If Used)

REVERSING CONTACTORS WITH "SUPER MAGNET" OPTION/OPEN TYPE Approximate Dimensions, mm

3ND0T0#22/SE
3ND1Q0#22/SE

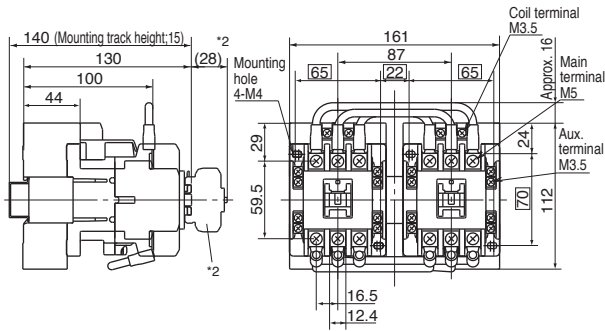

* 2 Aux. contact block. Front mounted (If Used)

3ND2F0#22/SE
3ND2H0#22/SE

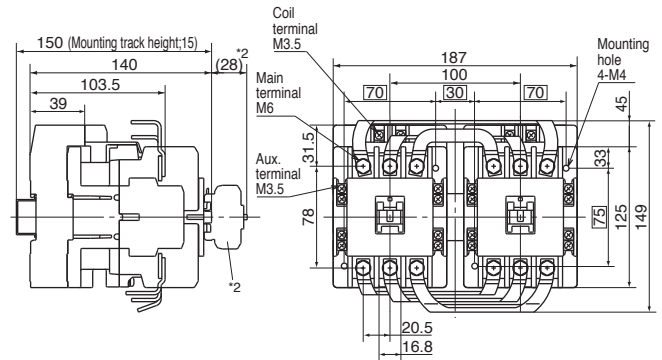

* 2 Aux. contact block. Front mounted (If Used)

3ND2T0#22/SE

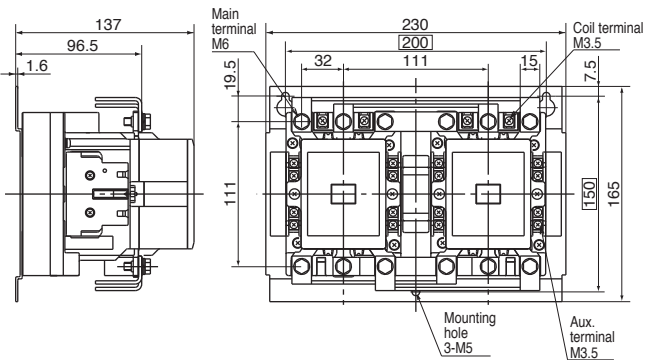

For exact mounting hole locations, please refer to the chart on page 48.

"ODYSSEY SERIES" Dimensions

■ THERMAL OVERLOAD RELAYS FOR USE WITH CONTACTORS Approximate Dimensions, mm

3NK1Q*

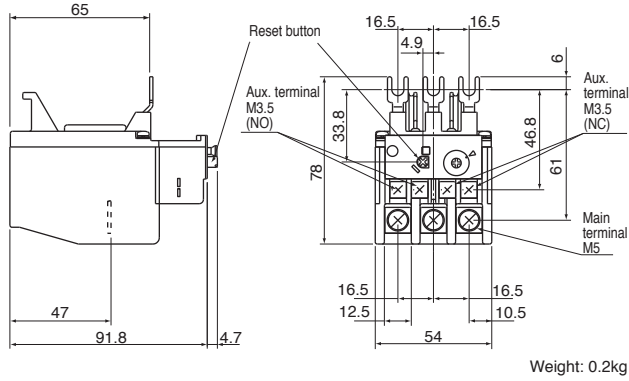

3NK2H*

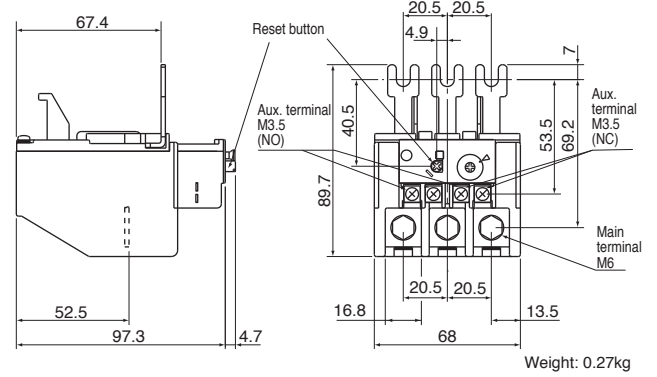

3NK3F*

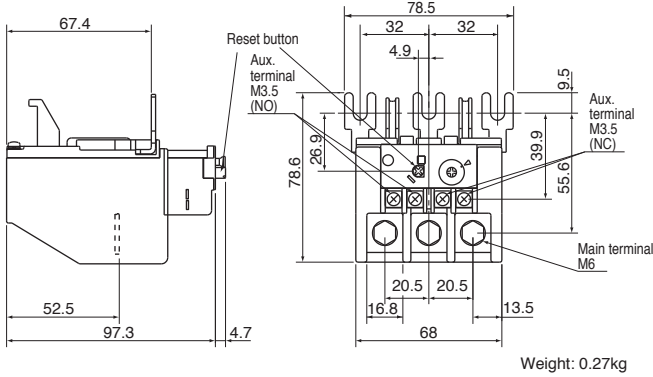

3NK3H*

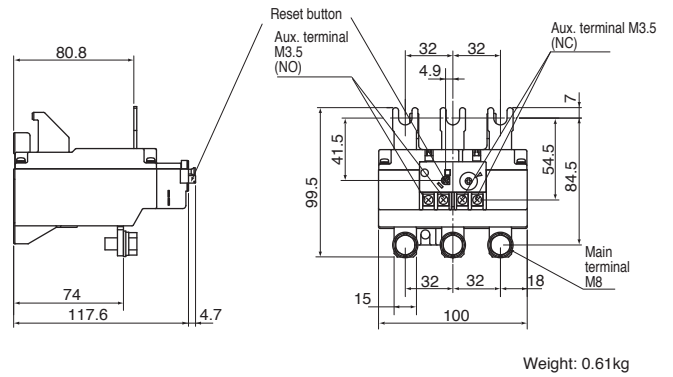

3NK4F*

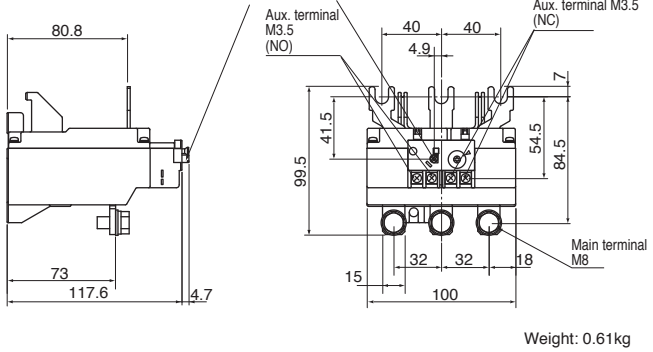

3NK4Q*

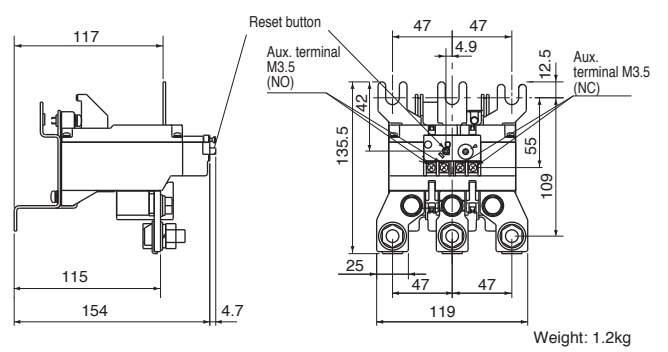

3NK4H*

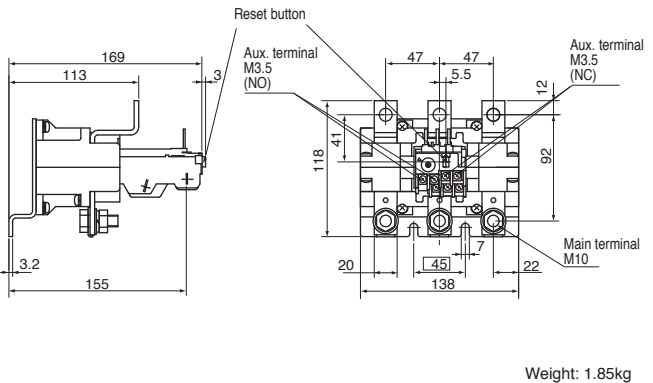

3NK5H*

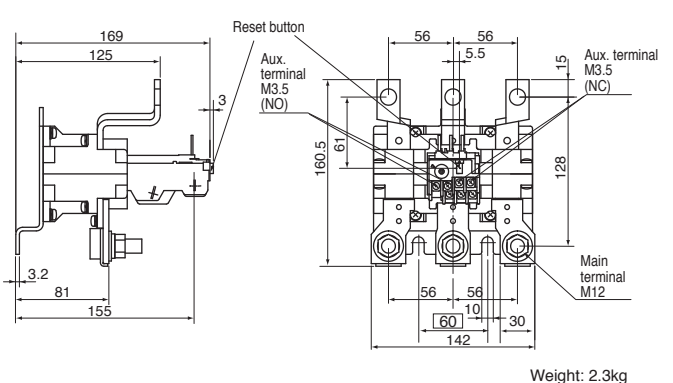

"ODYSSEY SERIES" Dimensions

■ THERMAL OVERLOAD RELAYS FOR "STAND ALONE" USE Approximate Dimensions, mm

3NK1Q* Installed in SZ-HD mounting bracket

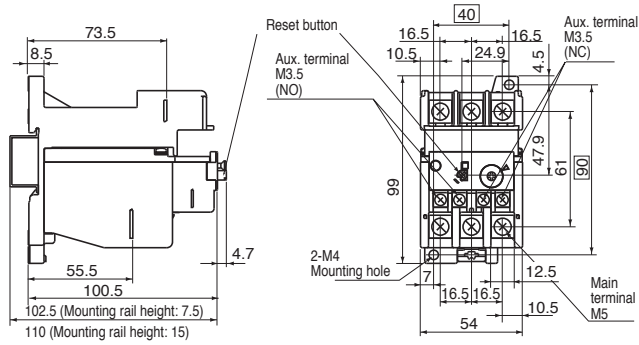

Available 4-42 Amps

Weight: 0.29kg

3NK2H* Installed in SZ-HE mounting bracket

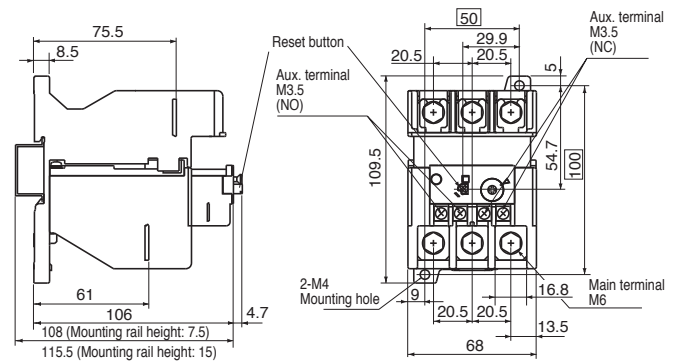

Available 7-68 Amps

Weight: 0.38kg

3NK3H*H (Specifically for "Stand Alone" use)

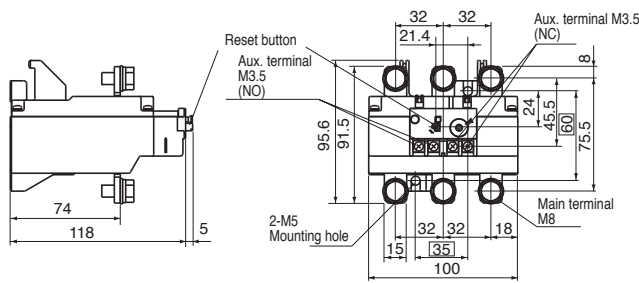

Available 45-125 Amps

Weight: 0.67kg

3NK4H*H (Specifically for "Stand Alone" use)

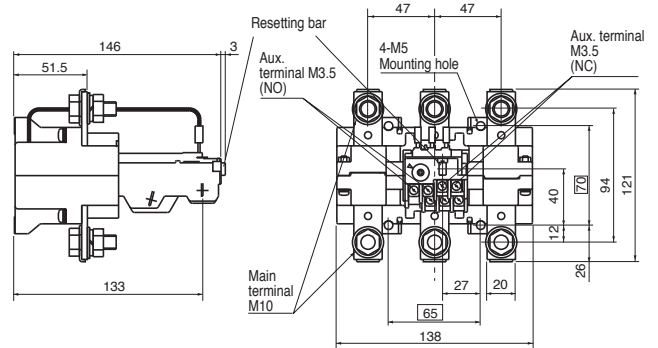

Available 85-240 Amps

Weight: 1.5kg

3NK5H*H (Specifically for "Stand Alone" use)

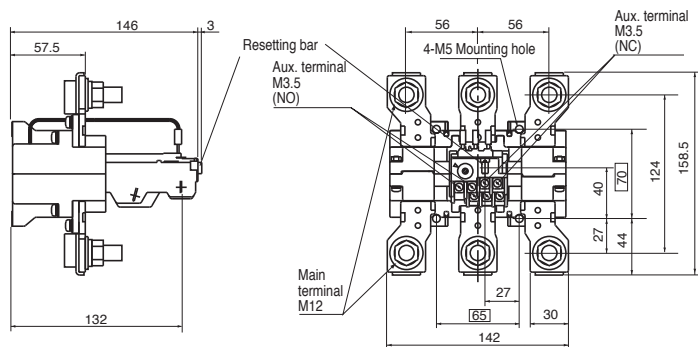

Available 110-450 Amps

Weight: 2.25kg

"ODYSSEY SERIES" Mounting Pitch Dimensions

■ NON-REVERSING CONTACTORS AND STARTERS Approximate Mounting Dimensions, mm

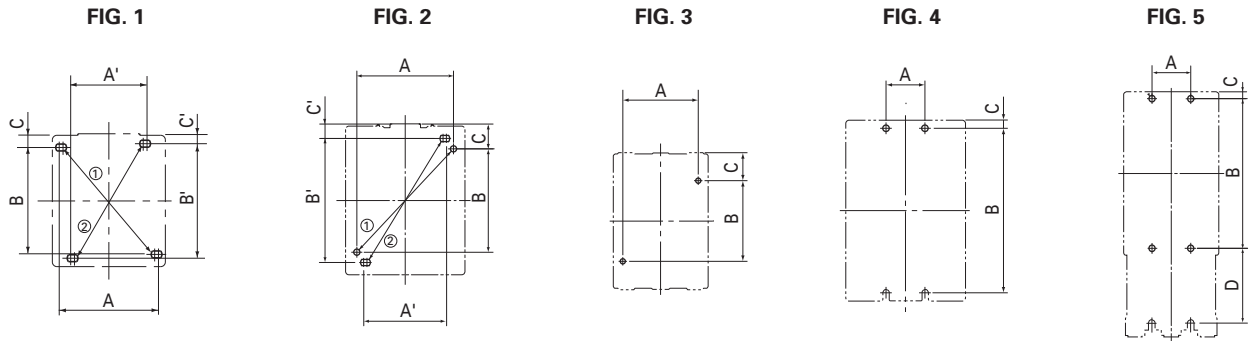

Frame Size	Contactors								Starters								
	Fig.No.	A	B	C	A'	B'	C'	Correct Screw Size	Fig.No.	A	B	C	A'	B'	C'	D	Correct Screw Size
0T	1	60-65	70	9	45-50	75	6.5	2-M4	1	60-65	70	9	45-50	75	6.5	-	2-M4
1Q	1	60-65	70	9	45-50	75	6.5	2-M4	1	60-65	70	9	45-50	75	6.5	-	2-M4
2F	2	70	75	18	55-60	90	10.5	2-M4	2	70	75	18	55-60	90	10.5	-	2-M4
2H	2	70	75	18	55-60	90	10.5	2-M4	2	70	75	18	55-60	90	10.5	-	2-M4
2T	3	70	75	26	-	-	-	2-M4	3	70	75	26	-	-	-	-	2-M4
3F	3	70	75	26	-	-	-	2-M4	3	70	75	26	-	-	-	-	2-M4
3H	3	80-90	110	17	-	-	-	2-M5	3	80-90	110	17	-	-	-	-	2-M5
4F	3	80-90	110	23	-	-	-	2-M5	3	80-90	110	23	-	-	-	-	2-M5
4Q	4	45	190	9.5	-	-	-	4-M6	4	45	270	9.5	-	-	-	-	4-M6
4H	4	45	190	9.5	-	-	-	4-M6	4	45	270	9.5	-	-	-	-	4-M6
5F	4	60	220	10	-	-	-	4-M8	5	60	220	10	-	-	-	110	4-M8
5H	4	60	220	10	-	-	-	4-M8	5	60	220	10	-	-	-	110	4-M8
6F & 6H	4	250	250	-	-	-	-	4-M10	-	-	-	-	-	-	-	-	-

■ REVERSING CONTACTORS AND STARTERS Approximate Mounting Dimensions, mm

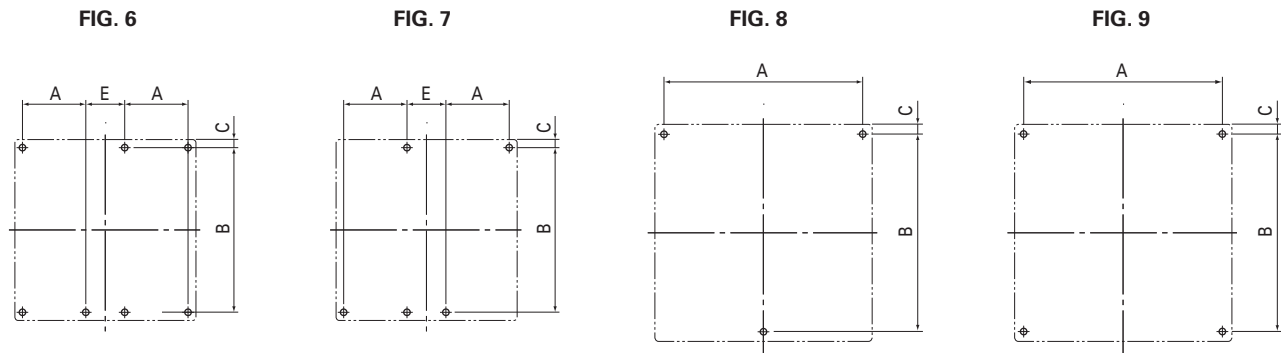

Frame Size	Reversing Contactors						Reversing Starters					
	Fig.No.	A	B	C	E	Correct Screw Size	Fig.No.	A	B	C	E	Correct Screw Size
0T	6	65	70	9	22	4-M4	6	65	70	9	22	4-M4
1Q	6	65	70	9	22	4-M4	6	65	70	9	22	4-M4
2F	7	70	75	18	30	4-M4	7	70	75	18	30	4-M4
2H	7	70	75	18	30	4-M4	7	70	75	18	30	4-M4
2T	8	200	150	7.5	-	3-M5	8	200	150	7.5	-	3-M5
3F	8	200	150	7.5	-	3-M5	8	200	150	7.5	-	3-M5
3H	8	220	175	7.5	-	3-M5	8	220	175	7.5	-	3-M5
4F	8	260	200	7.5	-	3-M6	8	260	200	7.5	-	3-M6
4Q	9	300	250	10	-	4-M6	9	300	350	10	-	4-M6
4H	9	300	250	10	-	4-M6	9	300	350	10	-	4-M6
5F	9	300	300	15	-	4-M8	9	300	450	15	-	4-M8
5H	9	300	300	15	-	4-M8	9	300	450	15	-	4-M8

TECHNICAL PERFORMANCE DATA

■ STANDARD CONDITIONS

- Ambient temperature should not exceed +40°C and the average over a period of 4 hours should not exceed +35°C. The lower limit of the ambient temperature is -5°C.
- Altitude Restriction
For use at altitudes exceeding 2000 meters (6,600 ft.) please consult Fuji Electric.

■ LIFE EXPECTANCY

Performance Data

Frame size	Current capacity Make/Break	Operating cycles per hour	Life expectancy (million operations)	
			Electrical	Mechanical
0A	12xIe/10xIe	1800	2	10
0F, 0G	12xIe/10xIe	1800	2	10
0Q	12xIe/10xIe	1800	1.5	10
0R, 0H	12xIe/10xIe	1800	2	10
0T, 1Q	12xIe/10xIe	1200	2	10
2F, 2H	12xIe/10xIe	1200	2	5
2T through 5F	12xIe/10xIe	1200	1	5
5H	12xIe/10xIe	1200	0.5	5

■ AUXILIARY CONTACT RATINGS

All Frame Sizes

Operating	Contact rating code designation	Continuous ampere rating	Current-Make/Break (A)			
			110 to 120V	220 to 240V	440 to 480V	550 to 600V
AC	A600	10	60/6	30/3	15/1.5	12/1.2
DC	Q300	10	120V		240V	
			0.55/0.55		0.27/0.27	

Note: Ie: Rated operational current.

Electrical life test: Conforming to IEC947-4-1, AC3.

The endurance test complies with the requirements of international standard IEC, JIS and JEM.

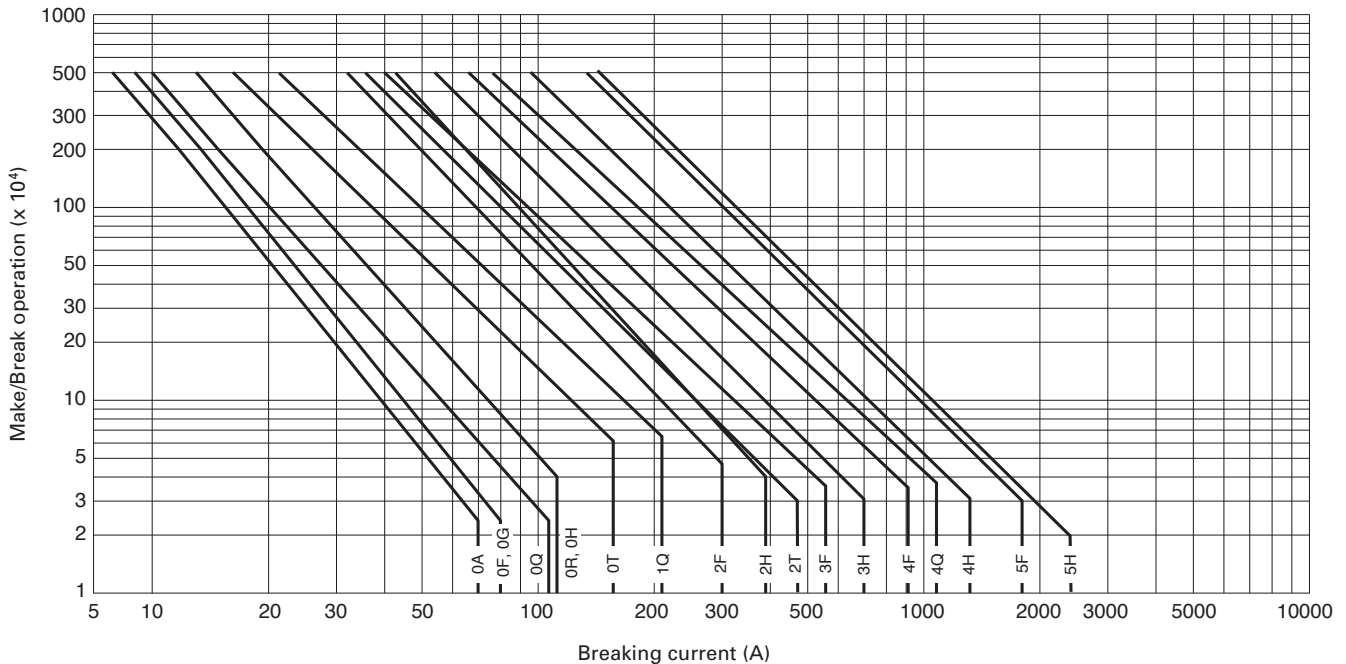

Terminal Tightening Torque Chart

Type No.		Terminal Size		Cable Size Maximum		Applicable Max. Width for Ring Terminal		Tightening Torque	
Contact or Starter	Thermal Overload Relay	Contact	Thermal Overload Relay	Contact	Thermal Overload Relay	Contact	Thermal Overload Relay	Contact	Thermal Overload Relay
4NC0A0 4NC0F0 4NC0G0 4NW0A0 4NW0F0 4NW0G0	4NK0A	M3.5	M3.5	12AWG (3.3mm ²)	12AWG (3.3mm ²)	7.7mm	7.7mm	7-9 in.lbs. 0.8-1 Nm	7-9 in.lbs. 0.8-1 Nm
4NC0Q0 4NC0R0 4NC0H0 4NW0Q0 4NW0R0 4NW0H0	4NK0H	M4	M4	10AWG (5.3mm ²)	10AWG (5.3mm ²)	9.7mm	9.7mm	11-13 in.lbs. 1.2-1.5 Nm	11-13 in.lbs. 1.2-1.5 Nm
3NC0T0 3NC1Q0 3NW0T0 3NW1Q0	3NK1Q	M5	M5	6AWG (13.3mm ²)	6AWG (13.3mm ²)	12.4mm	12.4mm	18-22 in.lbs. 2-2.5 Nm	18-22 in.lbs. 2-2.5 Nm
3NC2F0 3NC2H0 3NW2F0 3NW2H0	3NK2H	M6	M6	2AWG (33.6mm ²)	4AWG (21.2mm ²)	16.8mm	16.7mm	35-44 in.lbs. 4-5 Nm	35-44 in.lbs. 4-5 Nm
3NC2T0 3NC3F0 3NW2T0 3NW3F0	3NK3F	M6	M6	1/0AWG (53.5mm ²)	2AWG (33.6mm ²)	22.3mm	16.7mm	35-44 in.lbs. 4-5 Nm	35-44 in.lbs. 4-5 Nm
3NC3H0 3NW3H0	3NK3H	M8	M8	1/0AWG (53.5mm ²)	1/0AWG (53.5mm ²)	22.3mm	22.3mm	80-97 in.lbs. 9-11 Nm	80-97 in.lbs. 9-11 Nm
3NC4F0 3NW4F0	3NK4F	M8	M8	3/0AWG (85mm ²)	1/0AWG (53.5mm ²)	28.9mm	22.3mm	80-97 in.lbs. 9-11 Nm	80-97 in.lbs. 9-11 Nm
3NC4Q0 3NW4Q0	3NK4Q	M10	M10	300MCM (152mm ²)	300MCM (152mm ²)	36.5mm	36.5mm	133-177 in.lbs. 15-20 Nm	133-177 in.lbs. 15-20 Nm
3NC4H0 3NW4H0	3NK4H	M10	M10	300MCM (152mm ²)	300MCM (152mm ²)	36.5mm	36.5mm	133-177 in.lbs. 15-20 Nm	133-177 in.lbs. 15-20 Nm
3NC5F0 3NC5H0 3NW5F0 3NW5H0	3NK5H	M12	M12	400MCM (203mm ²)	400MCM (203mm ²)	44.5mm	44.5mm	310-399 in.lbs. 35-45 Nm	310-399 in.lbs. 35-45 Nm
3NC6F0 3NC6H0	-	M16	-	600MCM (304mm ²)	-	51.0mm	-	663-884 in.lbs. 75-100 Nm	-

COIL CHARACTERISTICS, AC COILS

COIL CHARACTERISTICS, AC COILS

Contactor Part Number	Power Consumption (VA)		Pick-up Voltage (V)	Drop-out Voltage (V)	Operating Time (ms)	
	Inrush	Sealed			Coil ON ↓ Contact ON	Coil OFF ↓ Contact OFF

Table 1, 110-120Vac Coils, Measured at 120VAC 60Hz

4NC0A0, 4NC0F0, 4NC0G0	95	9	58-68	40-55	9-20	5-16
4NC0Q0, 4NC0R0, 4NC0H0	95	9	65-73	44-60	9-20	5-16
3NC0T0, 3NC1Q0	135	12.4	60-70	43-58	10-17	6-13
3NC0T0.../SE, 3NC01Q.../SE	137	3.9	70-80	35-50	20-25	20-25
3NC2F0, 3NC2H0	190	13.4	65-75	50-60	10-18	8-18
3NC2F0.../SE, 3NC02H.../SE	168	3.8	70-80	35-50	23-28	24-29
3NC2T0	210	14.4	70-75	51-53	16-23	7-17
3NC2T0.../SE	130	3.9	70-80	35-50	32-36	30-33
3NC3F0	130	3.9	70-80	35-50	32-36	30-33
3NC3H0	210	4.4	70-80	35-50	32-36	30-33
3NC4F0	210	4.4	70-80	35-50	32-36	30-33
3NC4Q0, 3NC4H0	277	5.4	70-80	35-50	35-41	37-45
3NC5F0, 3NC5H0	265	5.9	70-80	35-50	40-47	36-43

Table 2, 220 - 240Vac Coils, Measured at 240VAC 60Hz

4NC0A0, 4NC0F0, 4NC0G0	95	9	128-150	88-121	9-20	5-16
4NC0Q0, 4NC0R0, 4NC0H0	95	9	143-161	97-132	9-20	5-16
3NC0T0, 3NC1Q0	135	12.4	132-154	94-127	10-17	6-13
3NC0T0.../SE, 3NC01Q.../SE	155	4.7	140-160	70-100	20-25	20-25
3NC2F0, 3NC2H0	190	13.4	143-165	110-132	10-18	8-18
3NC2F0.../SE, 3NC02H.../SE	190	4.8	140-160	70-100	23-28	24-29
3NC2T0	210	14.4	154-165	112-116	16-23	7-17
3NC2T0.../SE	115	5.1	140-160	70-100	32-36	30-33
3NC3F0	115	5.1	140-160	70-100	32-36	30-33
3NC3H0	275	6.5	140-160	70-100	32-36	30-33
3NC4F0	275	6.5	140-160	70-100	32-36	30-33
3NC4Q0, 3NC4H0	307	6.8	140-160	70-100	35-41	37-45
3NC5F0, 3NC5H0	417	7.1	140-160	70-100	40-47	36-43

Table 3, 24Vac Coils, Measured at 24VAC 60Hz

4NC0A0, 4NC0F0, 4NC0G0	95	9	14-16	10-13	9-20	5-16
4NC0Q0, 4NC0R0, 4NC0H0	95	9	16-18	11-14	9-20	5-16
3NC0T0, 3NC1Q0	135	12.4	14-17	10-14	10-17	6-13
3NC0T0.../SE, 3NC01Q.../SE	129	3.1	17-19.8	8-14.4	20-25	20-25
3NC2F0, 3NC2H0	190	13.4	16-18	12-14	10-18	8-18
3NC2F0.../SE, 3NC02H.../SE	144	2.6	17-19.8	8-14.4	23-28	24-29
3NC2T0	210	14.4	17-18	12-13	16-23	7-17
3NC2T0.../SE	98	3.6	17-19	8-14.4	32-36	30-33
3NC3F0	98	3.6	17-19	8-14.4	32-36	30-33
3NC3H0	165	4	17-19	8-14.4	32-36	30-33
3NC4F0	165	4	17-19	8-14.4	32-36	30-33
3NC4Q0, 3NC4H0	175	5.9	17-19	8-14.4	35-41	37-45
3NC5F0, 3NC5H0	225	6.3	17-19	8-14.4	40-47	36-43

COIL CHARACTERISTICS, DC COILS

■ COIL CHARACTERISTICS, DC COILS

Contactor Part Number	Power Consumption (VA)		Pick-up Voltage (V)	Drop-out Voltage (V)	Operating Time (ms)	
	Inrush	Sealed			Coil ON ↓ Contact ON	Coil OFF ↓ Contact OFF

Table 1, 110VDC Coils, Measured at 110VDC

4GC0A0, 4GC0F0	7	7	48-68	13-29	43-47	22-24
4GC0G0	7	7	47-67	15-31	43-47	22-24
4GC0Q0, 0R0	7	7	51-70	15-31	44-48	22-25
4GC0H0	7	7	51-72	17-33	45-49	22-26
3GC0T0, 3NC1Q0	9	9	44-66	17-39	40-48	17-21
3NC0T0.../SE, 3NC01Q.../SE	155	2.6	77-88	28-44	20-25	20-25
3GC2F0, 3GC2H0	12	12	44-66	13-33	60-70	15-19
3NC2F0.../SE, 3NC2H0.../SE	195	2.5	77-88	28-44	23-28	24-29
3NC2T0.../SE	112	2.6	77-88	28-44	32-36	30-33
3NC3F0	112	2.6	77-88	28-44	32-36	30-33
3NC3H0	255	3	77-88	28-44	32-36	30-33
3NC4F0	255	3	77-88	28-44	32-36	30-33
3NC4Q0, 3NC4H0	324	4.1	77-88	28-44	35-41	37-45
3NC5F0, 3NC5H0	340	4.5	77-88	28-44	40-47	36-43

Table 2, 24VDC Coils, Measured at 24VDC

4GC0A0, 4GC0F0	7	7	11-15	3-6	43-47	22-24
4GC0G0	7	7	10-15	3-7	43-47	22-24
4GC0Q0, 0R0	7	7	11-15	3-7	44-48	22-25
4GC0H0	7	7	11-16	4-7	45-49	22-26
3GC0T0, 3NC1Q0	9	9	10-14	4-8	40-48	17-21
3NC0T0.../SE, 3NC01Q.../SE	135	3	17-19.2	6-12	20-25	20-25
3GC2F0, 3GC2H0	12	12	10-14	3-7	60-70	15-19
3NC2F0.../SE, 3NC2H0.../SE	168	2.5	17-19.2	6-12	23-28	24-29
3NC2T0.../SE	105	3.4	17-19.2	6-12	32-36	30-33
3NC3F0	105	3.4	17-19.2	6-12	32-36	30-33
3NC3H0	200	3.9	17-19.2	6-12	32-36	30-33
3NC4F0	200	3.9	17-19.2	6-12	32-36	30-33
3NC4Q0, 3NC4H0	250	5.9	17-19.2	6-12	35-41	37-45
3NC5F0, 3NC5H0	305	6.3	17-19.2	6-12	40-47	36-43

AC CONTACTORS IN DC CIRCUITS

DC APPLICATIONS OF MAGNETIC CONTACTORS

DESCRIPTION

FUJI SC series magnetic contactors are normally used in AC circuit applications. However, they may also be used in DC circuits, and in this case their contacts must be connected in series as shown in the diagram.

When used in this manner they will be found to be more economical than using contactors exclusively designed for DC applications. Coils are available for both AC and DC.

if the following ratings are observed the equipment will have an electrical service life expectancy of 500,000 operations.

WIRING CONNECTION

Contactors must be connected in series when the contactors are used in DC applications.

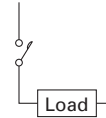

Series Contact 1

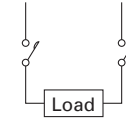

Series Contact 2

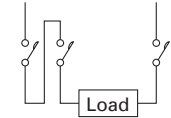

Series Contact 3

RATINGS

Frame Size	No. of Contacts Connected in Series	Rated Operational Current (A)							
		Resistive L/R ≤ 1ms.				DC MOTOR, L/R ≤ 15ms.			
		24V	48V	110V	220V	24V	48V	110V	220V
0A	1	13	13	10	1.2	6	3	2	0.35
	2	13	13	10	6	12	6	4	1.2
	3	15	15	15	15	15	10	8	4
0F	1	13	13	10	1.2	6	3	2	0.35
	2	13	13	10	6	12	6	4	1.2
	3	15	15	15	15	15	10	8	4
0G	1	13	13	10	1.2	6	3	2	0.35
	2	13	13	10	6	12	6	4	1.2
	3	15	15	15	15	15	10	8	4
0Q	1	16	13	10	1.5	8	6	2	0.35
	2	16	16	12	8	16	12	6	1.5
	3	18	18	18	15	18	18	12	6
0R	1	20	15	12	2	10	8	3	0.35
	2	20	20	15	10	20	15	8	2
	3	22	22	20	15	22	22	15	8
0H	1	20	15	12	2	10	8	3	0.35
	2	20	20	15	10	20	15	8	2
	3	22	22	20	15	22	22	15	8
0T	1	25	25	15	2	15	8	3	0.35
	2	25	25	25	20	25	15	8	2
	3	35	35	30	25	35	25	20	8
1Q	1	30	30	20	2	20	15	4	0.35
	2	30	30	30	20	30	20	15	3
	3	45	45	40	35	35	30	30	8
2F	2	60	60	40	20	60	30	20	3.5
	3	60	60	60	40	60	60	60	13
2H	2	80	80	50	20	80	40	20	4
	3	80	80	80	60	80	80	80	20
2T	2	80	80	50	20	80	40	20	4
	3	80	80	80	60	80	80	80	20
3F	2	120	120	80	40	120	80	40	15
	3	120	120	120	120	120	120	120	80
3H	2	120	120	80	40	120	80	40	15
	3	120	120	120	120	120	120	120	80
4F	2	160	160	100	80	160	120	80	40
	3	160	160	160	160	160	160	160	160
4Q	2	200	200	160	160	200	160	120	60
	3	200	200	200	200	200	200	200	200
4H	2	200	200	160	160	200	160	120	60
	3	200	200	200	200	200	200	200	200
5F	2	300	300	200	200	300	200	160	80
	3	300	300	300	300	300	300	300	300
5H	2	400	400	330	300	400	300	200	100
	3	400	400	400	400	400	400	400	400

These values represent usage in accordance with IEC specifications and are not recognized by UL508.

"ORANGE LINE" INDUSTRIAL RELAY

Features and Ratings

FEATURES

NEW SH SERIES EXPANDABLE INDUSTRIAL RELAY APPLICATIONS (U.S. Catalog No. 4SH and 4GH Series)

High contact reliability that accommodates electronic devices.

- All contacts are bifurcated, providing high contact reliability (minimum operational voltage and current: 5V and 3mA DC) and enabling direct input to an electronic control circuit.

A wide variety of optional units.

- In addition to an auxiliary contact block (two or four poles), many function units such as a coil surge suppression unit and terminal covers can be installed on standard industrial relays. This allows for flexibility and easy modification in the field.

Snap-on mounting on an IEC or DIN rail.

- All models can be mounted on an IEC or DIN Standard 35mm rail.

Meets International Standards.

- The SH Series industrial relays conform to the following International Standards: IEC, NEMA, BS and VDE. They are also UL, CSA, BV and Lloyd approved.

Compatible with conventional models.

- SH Series industrial relays are compatible with the discontinued Fuji SRCa50-3/X, SRCa50-3F/X, and SRC50-05/X

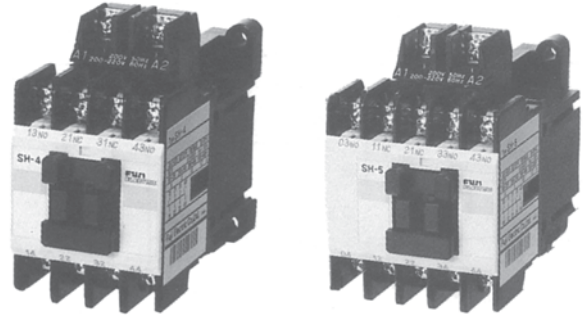

industrial relays. In addition to the mounting holes needed for the compatibility, mounting holes based on the IEC Standard are also provided.

Terminal numbers conforming to IEC Standards.

- Terminal numbers are based on IEC Standards.

New design.

- The arc extinguishing cover is ivory colored with orange accents, providing a new look to the conventional industrial relay.

AC OPERATED INDUSTRIAL RELAYS

U.S. Catalog No.	Aux. Contact	Fuji Type
4SH440#%	4NO	SH-4 4 POLE
4SH431#%	3NO+1NC	
4SH422#%	2NO+2NC	
4SH550#%	5NO	SH-5 5 POLE
4SH541#%	4NO+1NC	
4SH532#%	3NO+2NC	
4SH523#%	2NO+3NC	
4SH514#%	1NO+4NC	
4SH505#%	5NC	
4SH880#%	8NO	SH-4 8 POLE
4SH871#%	7NO+1NC	
4SH862#%	6NO+2NC	
4SH853#%	5NO+3NC	
4SH844#%	4NO+4NC	

DC OPERATED INDUSTRIAL RELAYS

U.S. Catalog No.	Aux. Contact	Fuji Type
4GH440#%	4NO	SH-4/G 4 POLE
4GH431#%	3NO+1NC	
4GH422#%	2NO+2NC	
4GH550#%	5NO	SH-5/G 5 POLE
4GH541#%	4NO+1NC	
4GH532#%	3NO+2NC	
4GH523#%	2NO+3NC	
4GH514#%	1NO+4NC	
4GH505#%	5NC	
4GH880#%	8NO	SH-4/G 8 POLE
4GH871#%	7NO+1NC	
4GH862#%	6NO+2NC	
4GH853#%	5NO+3NC	
4GH844#%	4NO+4NC	

EXPLANATION OF PART NUMBER SYSTEM

4 S H \$ @ @ # %

- APPROVAL**
4=UL Listed
JIS Approved

- OPERATION**
S=AC Coil
G=DC Coil

- DESCRIPTION**
H=Industrial Relay

- TOTAL NUMBER OF CONTACTS (Poles)**
4, 5 or 8

- TERMINAL OPTION**
Blank: Standard
Y: Optional, non-removable terminal cover accessory.

- COIL VOLTAGE**
Select code from chart on next page
For AC: use Table 1
For DC: use Table 2

QUANTITY OF AUX. CONTACTS

4 pole	5 pole	8 pole
40 : 4NO	50 : 5NO	80 : 8NO
31 : 3NO+1NC	41 : 4NO+1NC	71 : 7NO+1NC
22 : 2NO+2NC	32 : 3NO+2NC	62 : 6NO+2NC
	23 : 2NO+3NC	53 : 5NO+3NC
	14 : 1NO+4NC	44 : 4NO+4NC
	05 : 5NC	

"ORANGE LINE" INDUSTRIAL RELAY

Coil and Operating Characteristics, and Performance Data

AVAILABLE COILS

■ TABLE 1: AC Coils

Code Letter	AC coil 60Hz	AC coil 50Hz
E	24-26V	24V
F	48-52V	48V
A	100-110V	100V
1	110-120V	100-110V
G	120-130V	110-120V
B	200-220V	200V
2	220-240V	200-220V
4	440-480V	415-440V
5	550-600V	500-550V

■ TABLE 2: DC Coils

Code Letter	DC coil
T	12V
M	24V
N	48V
1	100V
R	110V
2	200V
S	220V

COIL CHARACTERISTICS

Power Consumption		Pick-Up Voltage (V)		Drop-Out Voltage (V)		Watt Loss (W)	
Inrush (VA)	Sealed (VA)	200V, 50Hz.	220V, 60Hz.	200V, 50Hz.	220V, 60Hz.	200V, 50Hz.	220V, 60Hz.
95	9	108-128	120-144	62-90	74-100	2.7	2.8

OPERATING CHARACTERISTICS

Coil Type	Voltage	Frequency (Hz)	Pick-Up Time (m sec.)		Drop-Out Time (m sec.)	
			No Contact ON	NC Contact OFF	NO Contact OFF	NC Contact ON
AC	200V AC	50	9-20	5-15	5-15	9-20
DC	200V DC	-	45-50	35-40	20-25	20-30

RATINGS UL File No. E44592, CSA File No. LR20479

Continuous Current (A)	Rated Operational Current (A)						Code	
	AC Volts	Make	Break	DC Volts	Make	Break	AC	DC
10	120	60	6	125	0.55	0.55	A600	Q300
	240	30	3	250	0.27	0.27		
	480	15	1.5					
	600	12	1.2					

PERFORMANCE DATA (AC11) Life Expectancy (Conforming to JIS C4531, JEM1230)

Operating Cycles Per Hour	Mechanical Life (Operations)	Electrical Life (Operations)				
		AC11		AC13		DC11, 14
		220V	440V	220V	440V	24V~220V
1,800	10 Million	500,000	500,000	250,000	250,000	500,000

"ORANGE LINE" INDUSTRIAL RELAY

Combinations and Contact Arrangements

COMBINATION OF INDUSTRIAL RELAY AND AUXILIARY CONTACT BLOCK

The standard type industrial relays can be used with a combination of the auxiliary contact blocks shown below.

Industrial Relay		Auxiliary Contact Block								
		Front Mounting					Side Mounting			
Type (U.S. Cat. No.)	Contact Arrangement	SZ-A40 4NO	SZ-A31 3NO + 1NC	SZ-A22 2NO + 2NC	SZ-A20 2NO	SZ-A11 1NO + 1NC	SZ-A02 2NC	SZ-AS1*1 2NO + 2NC	SZ-AS1 1NO + 1NC	SZ-AS1 1NO + 1NC
SH-4 (4SH4) • SH-4/G (4GH4)	4NO	8NO	7NO + 1NC	6NO + 2NC	6NO	5NO + 1NC	4NO + 2NC	6NO + 2NC	5NO + 1NC	5NO + 1NC
	3NO + 1NC 2NO + 2NC	7NO + 1NC 6NO + 2NC	6NO + 2NC 5NO + 3NC	5NO + 3NC 4NO + 4NC	5NO + 1NC 4NO + 2NC	4NO + 2NC 3NO + 3NC	3NO + 3NC 2NO + 4NC	5NO + 3NC 4NO + 4NC	4NO + 2NC 3NO + 3NC	4NO + 2NC 3NO + 3NC
SH-5 (4SH5) • SH-5/G (4GH5)	5NO	9NO	8NO + 1NC	7NO + 2NC	7NO	6NO + 1NC	5NO + 2NC	7NO + 2NC	6NO + 1NC	6NO + 1NC
	4NO + 1NC 3NO + 2NC 2NO + 3NC 1NO + 4NC 5NC	8NO + 1NC 7NO + 2NC 6NO + 3NC 5NO + 4NC 4NO + 5NC	7NO + 2NC 6NO + 3NC 5NO + 4NC - -	6NO + 3NC 5NO + 4NC - -	6NO + 1NC 5NO + 2NC 4NO + 3NC 3NO + 4NC 2NO + 5NC	5NO + 2NC 4NO + 3NC 3NO + 4NC - -	4NO + 3NC 3NO + 4NC - -	5NO + 4NC 5NO + 4NC - -	6NO + 1NC 5NO + 2NC 4NO + 3NC 3NO + 4NC -	6NO + 1NC 5NO + 2NC 4NO + 3NC 3NO + 4NC -

Note: Auxiliary contact blocks cannot be mounted both front mounting and side mounting at the same time.
*1: 2PCS needed to make 2NO+2NC

CONTACT ARRANGEMENT

U.S. Catalog No.	Fuji Type	Contact Arrangement	
		NO	NC
4SH440# 4GH440#	SH-4 4-Pole • SH-4/G 4-Pole	4NO	
4SH431# 4GH431#	SH-4 4-Pole • SH-4/G 4-Pole	3NO + 1NC	
4SH422# 4GH422#		2NO + 2NC	
4SH880# 4GH880#		* SH-4 8-Pole • SH-4/G 8-Pole	8NO
4SH871# 4GH871#	SH-4 8-Pole • SH-4/G 8-Pole	7NO + 1NC	
4SH862# 4GH862#		6NO + 2NC	
4SH853# 4GH853#		5NO + 3NC	
4SH844# 4GH844#		4NO + 4NC	

U.S. Catalog No.	Fuji Type	Contact Arrangement	
		NO	NC
4SH550# 4GH550#	SH-5 5-Pole • SH-5/G 5-Pole	5NO	
4SH541# 4GH541#		4NO + 1NC	
4SH532# 4GH532#		3NO + 2NC	
4SH523# 4GH523#		2NO + 3NC	
4SH514# 4GH514#		1NO + 4NC	
4SH505# 4GH505#		5NC	

*Note: 8 pole units are made from standard 4 pole frames with 4 pole Aux. contacts added. The 5 available configurations are made as follows:

- 4_H880# (8NO, no NC) = 4_H440# Base + SZ-A40 Aux.
- 4_H871# (7NO + 1 NC) = 4_H440# Base + SZ-A31 Aux.
- 4_H862# (6NO + 2 NC) = 4_H440# Base + SZ-A22 Aux.
- 4_H853# (5NO + 3 NC) = 4_H422# Base + SZ-A31 Aux.
- 4_H844# (4NO + 4 NC) = 4_H422# Base + SZ-A22 Aux.

"ORANGE LINE" INDUSTRIAL RELAY

Dimensions

■ **DIMENSIONS:** mm (inches)

SH-4/4-Pole (U. S. Catalog No. 4SH4)

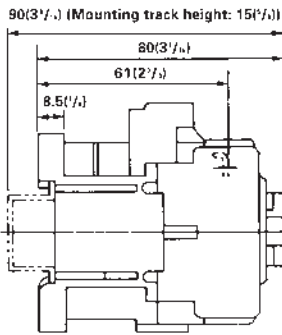

Net weight: 0.32kg (.71 lbs.)

SH-4/G, 4-Pole (U. S. Catalog No. 4GH4)

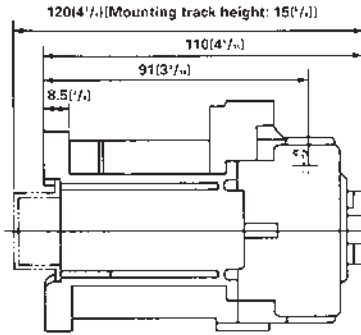

Net weight: 0.55kg (1.2 lbs.)

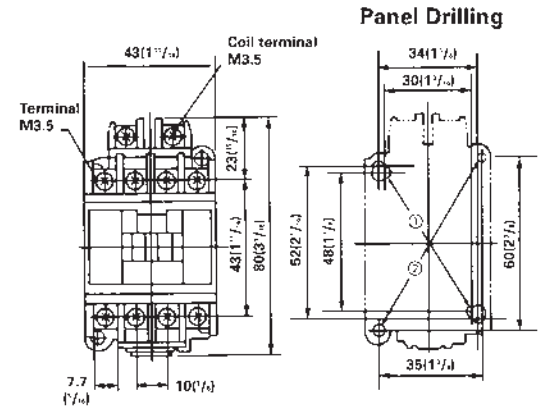

SH-4/8-Pole (U. S. Catalog No. 4SH8)

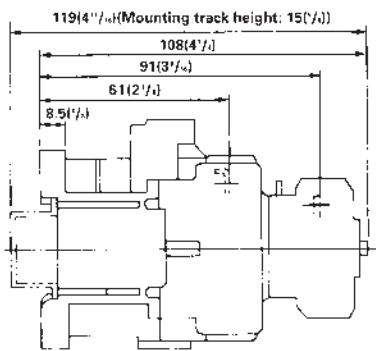

Net weight: 0.36kg (.8 lbs.)

SH-4/G, 8-Pole (U. S. Catalog No. 4GH8)

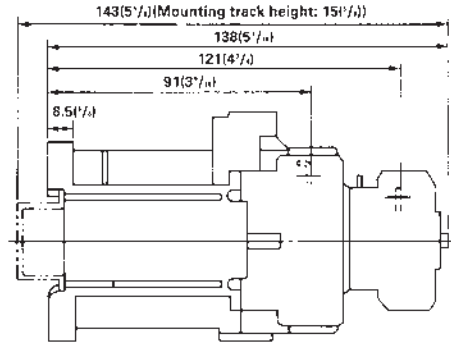

Net weight: 0.59kg (1.3 lbs.)

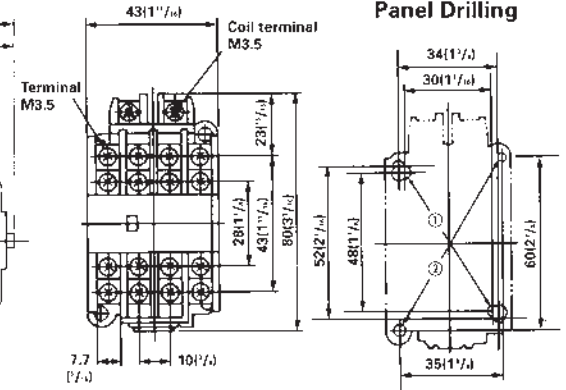

SH-5/5-Pole (U. S. Catalog No. 4SH5)

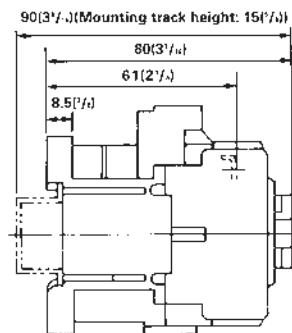

Net weight: 0.34kg (.75 lbs.)

SH-5/G, 5-Pole (U. S. Catalog No. 4GH5)

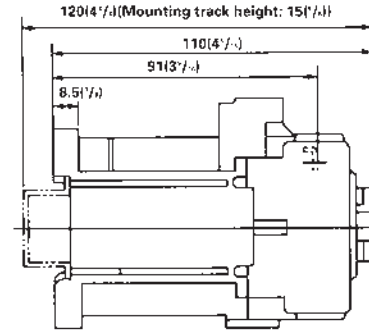

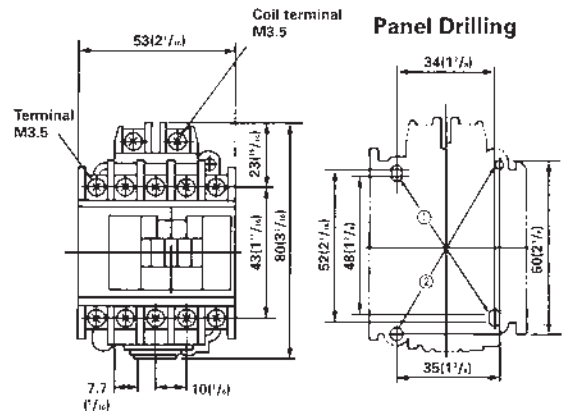

Net weight: 0.58kg (1.3 lbs.)



Notes: Panel Drilling -

- Use the two mounting holes on a diagonal line to mount a relay.
- Mounting holes indicated by ① are compatible with those of SRC type.
- Mounting holes indicated by ② conform to IEC Standards.

"SK SERIES" Mini Contactors, Quick Selection Guide

Contactor	AC-operated	SK06A	SK09A	SK12A
	DC-operated	SK06G	SK09G	SK12G
				
"3Phase HP Rating [HP] (AC-3)	200V 220-240V 400-480V	1 1/2 2 3	2 3 5	3 3 5
UL508 "	500-600V	5	5	5
"Full Load Ampere Rating [A] (AC-3)"	200V 220-240V 400-480V 500-600V	6.9 6.6 6.8 6.1	7.8 7.5 9.6 6.1	11 10.6 7.6 6.1
Rated Thermal Current [A] (AC-1)		20	20	20
Auxiliary Contact Arrangement		1NO, 1NC	1NO, 1NC	1NO, 1NC
Dimensions (mm)	AC-operated	H48*W45*D49		
	DC-operated	H48*W45*D49		
Standards		UL 508, CSA 22.2, IEC 60947-1, EN 60947-4-1, VDE 0660		
Thermal Overload Relay TK12				
Ampere Range Code	P10	0.1-0.15A		
	P13	0.13-0.2A		
	P18	0.18-0.27A		
	P24	0.24-0.36A		
	P34	0.34-0.52A		
	P48	0.48-0.72A		
	P64	0.64-0.96A		
	P80	0.8-1.2A		
	P95	0.95-1.45A		
	1P4	1.4-2.1A		
	1P7	1.7-2.6A		
	2P2	2.2-3.4A		
	2P8	2.8-4.2A		
	004	4-6A		
	005	5-7.5A		
	006	6-9A		
007	7-10.5A			
009	9-13A			
Dimensions		H61.5*W45*D50		
Standards		UL 508, CSA 22.2, IEC 60947-1, EN 60947-4-1, VDE 0660		

"SK SERIES" Mini Contactors, Type Number Nomenclature

■ Type Number Nomenclature

● Type Number Nomenclature (Type Number = Product Code)

• Magnetic Contactors

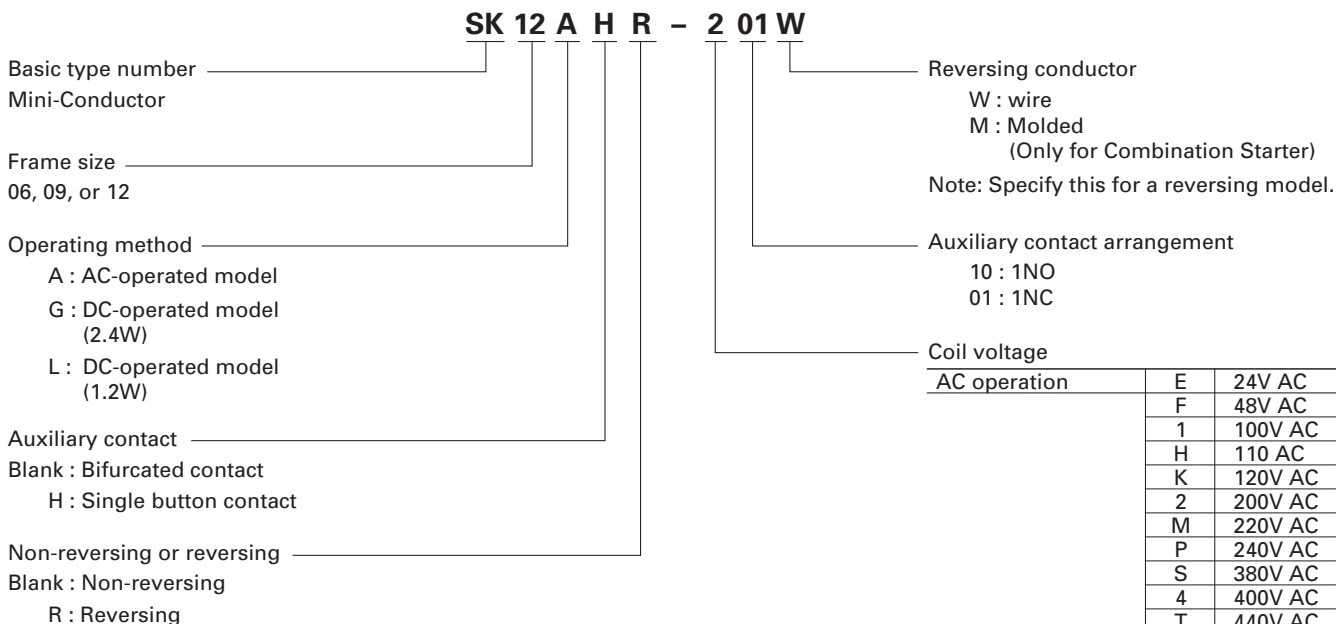

AC operation	E	24V AC	
	F	48V AC	
	1	100V AC	
	H	110 AC	
	K	120V AC	
	2	200V AC	
	M	220V AC	
	P	240V AC	
	S	380V AC	
	4	400V AC	
DC operation	2.4W	T	440V AC
		5	500V AC
		B	12V DC
		E	24V DC
		F	48V DC
	1.2W	G	60V DC
		1	100 DC
		H	110V DC
		K	120V DC
		2	200V DC
1.2W	Y	210V DC	
	M	220V DC	
	B	12V DC	
	E	24V DC	
	F	48V DC	

Note: Products cannot be manufactured for all possible type numbers.

• Thermal Overload Relays

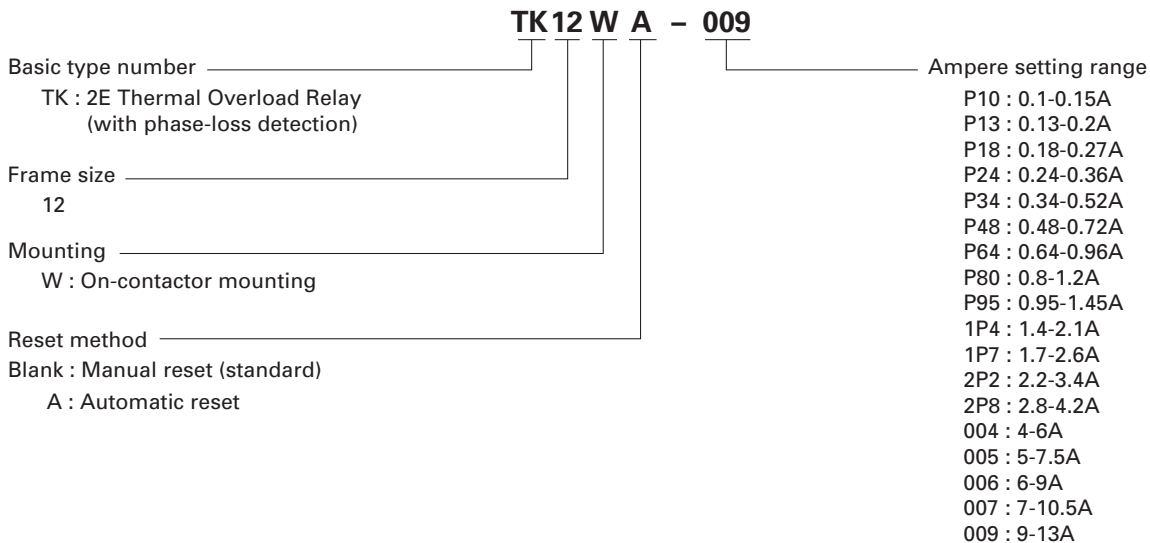

"SK SERIES" Mini Contactors, Ratings

■ Available Coils

AC Coil Voltages		
Code	AC Coil 60Hz	AC Coil 50Hz
E	24-26V	24V
F	48-52V	48V
1	100-110V	100V
H	110-120V	100-110V
K	120-130V	110-120V
2	200-220V	200V
M	220-240V	200-220V
P	240-260V	220-240V
S	380-420V	346-380V
4	400-440V	380-400V
T	440-480V	415-440V
S	500-550V	480-500V

DC Coil Voltages (2.4W)	
Code	DC Coil
B	12V
E	24V
F	48V
G	60V
1	100V
H	110V
K	120V
2	200V
Y	210V
M	220V

DC Coil Voltages (1.2W)	
Code	DC Coil
B	12V
E	24V
F	48V

■ Operating Coil Characteristics

• AC-operated Models

Type	Power consumption [VA]				Watt loss [W]		Pick-up voltage [V]		Drop-out voltage [V]		Operating times [ms]	
	Inrush		Sealed		200V	200V	50Hz	60Hz	50Hz	60Hz	Coil ON → Contact ON	Coil OFF → Contact OFF
SK06A	200V	200V	200V	200V	200V	200V	50Hz	60Hz	50Hz	60Hz	17-26	8-11
SK09A	50Hz	60Hz	50Hz	60Hz	50Hz	60Hz						
SK12A	22	25	4.5	4.5	1.2	1.3	122-135	128-138	80-89	83-96		

Note 1. The characteristics are for the following coil ratings: 200V, 50Hz/200 to 220V, 60Hz.

Note 2. The electromagnet capacity is the same even when the rated coil voltage is not 200V AC.

Note 3. The operating times are for 200V AC, 50Hz.

Note 4. The pick-up voltage and drop-out voltage for a 100V (100V AC, 50Hz/100 to 110V, 60Hz) coil are approximately half of the values that are given in the above table.

Note 5. The values in the above table are example for a cold status at 20°C.

• DC-operated Models (2.4W)

Type	Power consumption [VA]		Time constant [ms]	Pick-up voltage [V]	Drop-out voltage [V]	Operating times [ms]	
	Inrush	Sealed				Coil ON → Contact ON	Coil OFF → Contact OFF
SK06G	24V	24V	Sealed			22-24	5-6
SK09G							
SK12G	2.4	2.4	20	10-11	4-6		

Note 1. The characteristics are for the following coil ratings: 24V DC.

Note 2. The electromagnet capacity is the same even when the rated coil voltage is not 24V DC.

Note 3. The values in the above table are example for a cold status at 20°C.

• DC-operated Models (1.2W)

Type	Power consumption [VA]		Time constant [ms]	Pick-up voltage [V]	Drop-out voltage [V]	Operating times [ms]	
	Inrush	Sealed				Coil ON → Contact ON	Coil OFF → Contact OFF
SK06L	24V	24V	Sealed			30-33	8-9
SK09L							
SK12L	1.2	1.2	20	13-14	4-5		

Note 1. The characteristics are for the following coil ratings: 24V DC.

Note 2. The electromagnet capacity is the same even when the rated coil voltage is not 24V DC.

Note 3. The values in the above table are example for a cold status at 20°C.

■ Auxiliary Circuit Ratings

• UL/CSA-conformance Ratings (Bifurcated Contact or Single Button Contact)

Type	Rated continuous current [A]	Rated operational current [A]						Rating code	
		AC			DC			AC	DC
		Rated operational voltage [V]	Making	Breaking	Rated operational voltage [V]	Making	Breaking		
SK06	10	120	60	6	125	0.55	0.55	A600	Q300
SK09		240	30	3					
SK12		480	15	1.5	250	0.27	0.27		
SKH4		600	12	1.2					

"SK SERIES" Thermal Overload Relays

Auxiliary Circuit Ratings

Ratings for UL and CSA Standard Compliance

Type	Rated continuous current [A]	Rated operational current [A]						Rating code	
		AC			DC			AC	DC
		Rated operational voltage [V]	Making	Breaking	Rated operational voltage [V]	Making	Breaking		
TK12	5	120	30	3	125	0.22	0.22	B600	R300
		240	15	1.5					
		480	7.5	0.75	250	0.11	0.11		
		600	6	0.6					

Operating Characteristics (Specifications)

3-pole circuits

Standard	Operating limit		Overload (hot start)	Locked rotor (cold start)	Ambient temperature
	Non-tripping	Tripping			
IEC 60947-4-1	105% I _e (for less than 2h)	120% I _e (for less than 2h)	Tripping class 10A : 150% I _e for less than 2min	Tripping class 10A : 720% I _e for 2 to 10 s max	20°C

2-pole circuits

Standard	Phase-loss protection	Non-tripping	Overload (hot start)	Ambient temperature
IEC 60947-4-1	Provided	2-pole : 100% I _e 1-pole : 90% I _e	2-pole: 115% I _e (for less than 2h) 1-pole: 0% I _e	20°C

Operating Characteristics Curves (Average Values)

Tripping Class 10A

TK12 series, Ambient temperature: 20°C

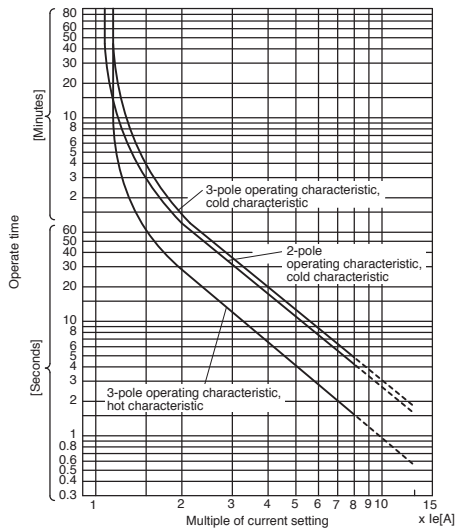

Dimensions, mm

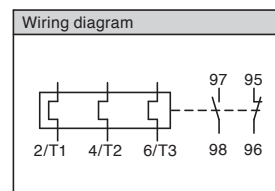
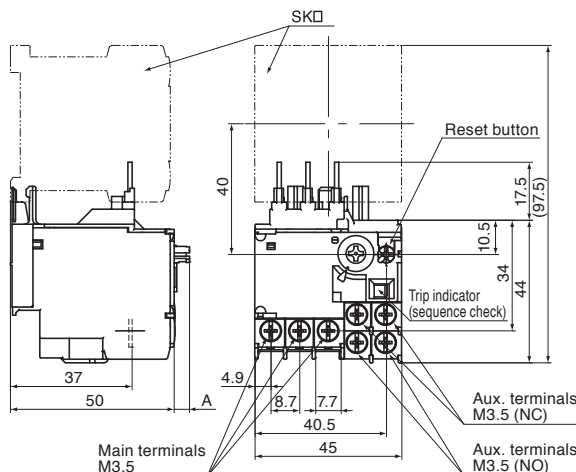

Mass : 0.1kg

Dimension A
- Manually reset state: 5mm
- Automatically reset state: 2mm

"SK SERIES" Mini Contactors, Accessories

Auxiliary Contact Blocks w/ Bifurcated Contacts

Applicable contactors	Mounting	No. of contact	Contact Arrangements	Part Number
SK06 *1 SK09 *1 SK12 *1	Front mounting	4	4NO	SZ1KA40
			3NO+1NC	SZ1KA31
			2NO+2NC	SZ1KA22
			1NO+3NC	SZ1KA13
			4NC	SZ1KA04
SK06 SK09 SK12	Front mounting	2	2NO	SZ1KA20
			1NO+1NC	SZ1KA11
			2NC	SZ1KA02

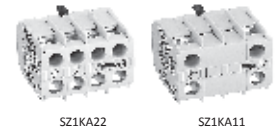

*1 These contact blocks cannot be used with 1.2W DC Magnetic Contactors (SK06L - SK12L) & SKH4L Auxiliary Relays

Main Surge Suppression Unit

Applicable contactors	Mounting	Rated Voltage, Frequency	Applicable 3-Phase Motors	Part Number
SK06 SK09 SK12	Independent Mounting	250VAC, 50/60Hz	"200 to 240VAC, 0.1 to 2.2kW"	SZ-ZM2 + SZ-ZMH

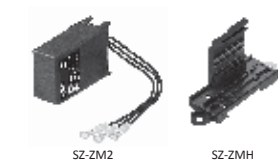

Coil Surge Suppression Unit

Applicable contactors	Surge Suppression Element	Operating Coil Voltage	Operation Indicator Lamp	Part Number
SK06A SK09A SK12A	Varistor	24-48VAC	-	SZ1KZ1
		48-125VAC	-	SZ1KZ2
		100-240VAC	-	SZ1KZ3
		24-48VAC	-	SZ1KZ4
		48-125VAC	-	SZ1KZ5
SK06G SK09G SK12G	Varistor included	Unnecessary (Built-in suppression)	-	-



Power Connection Kit for Reversing

Applicable contactors	Wire size	Number of conductors per set	Description	Part Number
SK06 SK09 SK12	"AWG14 (1.6mm dia.)"	"One set for line side One set for load side"	"Wire Type (another contactor)"	SZ1KRW1W
			For Combination Starter	SZ1KRW1M

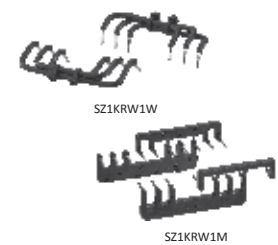

Mechanical Interlock

Applicable contactors	Description	Part Number
SK06 SK09 SK12	Used for reversing contactor	SZ1KRM



Link Module

Applicable contactors	Applicable MMS	Description	Part Number
SK06 SK09 SK12	BM3RSB BM3RHB	Electrically & Mechanically connects MMS & SK contactor	BZ0LRK12AA



Thermal Overload Relay Reset Releases

Applicable Overload Relay	Release Length [mm]	Description	Part Number
TK12	300	Resets TOR from front surface of panel or remote location	SZ-R1
	500		SZ-R2
	700		SZ-R3



"SK SERIES" Mini Contactors, Auxiliary Relays

■ Features

- International safety standards for standard models (IEC, GB, JIS, UL, and CSA).
- Models available with AC, DC, or low-power DC operating coils.
- Bifurcated contact for more reliable contact for micro-loads of 3mA at 5V DC.
- Models with high-capacity contacts (single button contact) are also available.
- Configure a wide range of contacts in combination with Auxiliary Contact Blocks.



SKH4A

■ Ordering Information (Types)

- Auxiliary Relays

SKH4 A H - E 22

① ② ③ ④ ⑤

① Series ② Operating coil ③ Contact specification ④ Coil voltage specification ⑤ Contact arrangement

■ Ratings

Refer to Auxiliary Contact Ratings on page 60.

■ Types

Operating coil specification ②	Contact specification ③	Coil voltage specification ④	Contact arrangement ⑤	Type
AC-operated models [A]	Bifurcated contact [blank]	24V [E] 120V [K] 380V [S]	4NO	SKH4A-□40
		48V [F] 200V [2] 400V [4]	3NO+1NC	SKH4A-□31
		100V [1] 220V [M] 440V [T]	2NO+2NC	SKH4A-□22
	Single button contact [H]	110V [H] 240V [P] 500V [5]	4NO	SKH4AH-□40
			3NO+1NC	SKH4AH-□31
			2NO+2NC	SKH4AH-□22
DC-operated models (2.4W) [G]	Bifurcated contact [blank]	12V [B] 100V [1] 210V [Y]	4NO	SKH4G-□40
		24V [E] 110V [H] 220V [M]	3NO+1NC	SKH4G-□31
		48V [F] 120V [K]	2NO+2NC	SKH4G-□22
	Single button contact [H]	60V [G] 200V [2]	4NO	SKH4GH-□40
			3NO+1NC	SKH4GH-□31
			2NO+2NC	SKH4GH-□22
DC-operated models (1.2W) [L]	Bifurcated contact [blank]	12V [B]	4NO	SKH4L-□40
		24V [E]	3NO+1NC	SKH4L-□31
		48V [F]	2NO+2NC	SKH4L-□22
	Single button contact [H]		4NO	SKH4LH-□40
			3NO+1NC	SKH4LH-□31
			2NO+2NC	SKH4LH-□22

Note. "□" in the type column is replaced with the coil voltage code.

"SK SERIES" Mini Contactors, Auxiliary Relays

Auxiliary Relays

■ Type Number Nomenclature

- Type Number Nomenclature
 - SK-Series Auxiliary Relays

SKH4 A H - 1 22

Basic type _____
SK-Series Auxiliary Relay

Operating method _____
 A : AC-operated models
 G : DC-operated models (2.4W)
 L : DC-operated models (1.2W)

Auxiliary contact _____
 Blank : Bifurcated contact
 H : Single button contact

Auxiliary contact arrangement
 40 : 4NO
 31 : 3NO+1NC
 22 : 2NO+2NC

Coil voltage

AC operation			
		E	24V AC
		F	48V AC
		1	100V AC
		H	110 AC
		K	120V AC
		2	200V AC
		M	220V AC
		P	380V
		S	AC
		4	400V AC
		T	440V AC
		5	500V AC
DC operation			
2.4W		B	12V DC
		E	24V DC
		F	48V DC
		G	60V DC
		1	100 DC
		H	110V DC
		K	120V DC
		2	200V DC
		Y	210V DC
		M	220V DC
1.2W		B	12V DC
		E	2V DC
		F	48V DC

"SK SERIES" Mini Contactors, Auxiliary Relays

■ Performances

- Durability (Based on IEC 60947-5-1)

Type	Number of contacts	Operating cycles per hour [times/hour]	Mechanical durability	Electrical durability					
				AC-15		AC-12		DC-13	DC-12
				220V	440V	220V	440V	220V	220V
SKH4	4	1800	10 million	500,000	500,000	250,000	250,000	250,000	500,000

■ Combinations with Auxiliary Contact Blocks

SK-Series Auxiliary Relays and Auxiliary Contacts Blocks can be combined as shown in the following table. Other combinations are not possible.

Auxiliary Relay type	Auxiliary Contact Block	Type	SZ1KA40 SZ1KA40H	SZ1KA31 SZ1KA31H	SZ1KA22 SZ1KA22H	SZ1KA13 SZ1KA13H	SZ1KA04 SZ1KA04H	SZ1KA20 SZ1KA20H	SZ1KA11 SZ1KA11H	SZ1KA02 SZ1KA02H	SZ1FA11 SZ1FA11H
	Auxiliary contact arrangement	Combined auxiliary contact arrangement									
SKH4A SKH4AH SKH4G SKH4GH	4NO	8NO	7NO+1NC	6NC+2NC	5NO+3NC	4NO+4NC	6NO	5NO+1NC	4NO+2NC	5NO+1NC	
	3NO+1NC	7NO+1NC	6NO+2NC	5NO+3NC	4NO+4NC	3NO+5NC	5NO+1NC	4NO+2NC	3NO+3NC	4NO+2NC	
	2NO+2NC	6NO+2NC	5NO+3NC	4NO+4NC	3NO+5NC	2NO+6NC	4NO+2NC	3NO+3NC	2NO+4NC	3NO+3NC	
SKH4L SKH4LH	4NO	-	-	-	-	-	6NO	5NO+1NC	4NO+2NC	5NO+1NC	
	3NO+1NC	-	-	-	-	-	5NO+1NC	4NO+2NC	3NO+3NC	4NO+2NC	
	2NO+2NC	-	-	-	-	-	4NO+4NC	3NO+3NC	2NO+4NC	3NO+3NC	

■ Linked Contact Compliance (Compliance with Requirements of IEC60947-5-1 Annex L)

Auxiliary Relay type	Auxiliary Contact Block	No Auxiliary Contact Block	SZ1KA□		SZ1FA11	SZ1KA□H		SZ1FA11H
			4-pole	2-pole		4-pole	2-pole	
SKH4A SKH4AH		○	x	x	x	x	x	x
SKH4G SKH4GH		○	x	x	○	○	○	○
SKH4L SKH4LH		○	-	○	○	-	○	○

- : Complies.
- x : Does not comply.

■ Dimensions, mm

SKH4

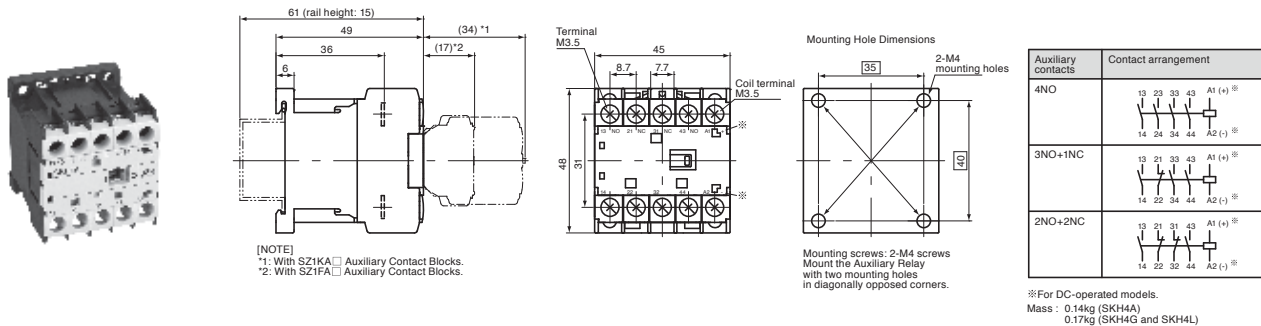

SF SERIES

MAGNETIC CONTACTORS SF SERIES

DESCRIPTION

FUJI SF series contactors are designed for use in consumer products and light industrial machinery and equipment. They are recommended for applications which call for economy, easy handling and reliability.

Typical applications include air conditioners, show cases, industrial washing machines, heaters, pumps, fans, compressors, dryers and vending machines. They are available in sizes ranging up to 30kW at 440 Volts AC.

FEATURES

- Small size, light weight
- Budget priced
- Long service life
Electrical life expectancy: 250,000 operations. Good for 7 years service if they are operated 100 times a day.
- Scrubbing action
The contacts are self-cleaning by a scrubbing action during operation and are made of a silver alloy.
- Highly reliable operating coil
Pick-up voltage 75% of rated voltage
- Self-lifting terminals
Easy to wire

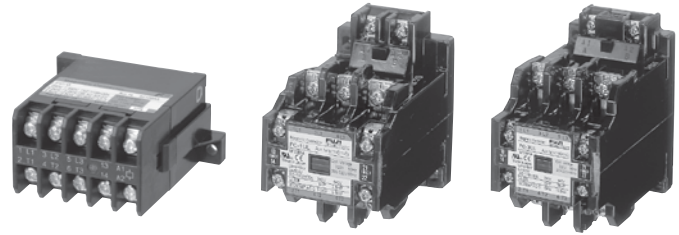

CONSTRUCTION

- Their small size permits them to be mounted in positions where space is limited and they can be mounted in a variety of directions.
- The standard terminals are screw-type. Printed board type and tab terminals are also available.
- The contact section is housed inside the molded frame and is totally enclosed. The dust-tight construction keeps contact performance at a high level and results in a long trouble-free service life.

ORDERING INFORMATION

Specify the following:

1. Ordering code
2. Operating coil voltage code
3. Auxiliary contact arrangement

TYPES AND RATINGS (IEC60947-4-1)

Motor capacity (kW) AC-3 3-phase		Operational current (A) AC-3 3-phase		Operational current (A) AC-1 *2	Auxiliary contact		Non-reversing Open		Frame
200V 240V	380V 440V	200V 240V	380V 440V		NO	NC	US PIN	Fuji Type	
3	2.5	12	6	20	1	–	SF12B1A-■10	FC-0UL	0
3	2.5	12	6	20	–	1	SF12B1A-■01	FC-0UL	0
3.5	4.5	15	10	20	1	–	SF15B1A-■10	FC-0SUL	0S
3.5	4.5	15	10	20	–	1	SF15B1A-■01	FC-0SUL	0S
5.5	5.5	20	13	30	1	1*1	SF20B1A-■11	FC-1UL	1
7.5	7.5	27	18	30	1	1*1	SF26B1A-■11	FC-1SUL	1S
1.5	–	8	–	8	1	–	SF08BBA-■10	FC-0A	0A
1.5	–	8	–	8	–	1	SF08BBA-■01	FC-0A	0A
3	2.5	12	6	20	1	–	SF12B3A-■10	FC-0TUL	0T
3	2.5	12	6	20	–	1	SF12B3A-■01	FC-0TUL	0T
3.5	4.5	15	10	20	1	–	SF15B3A-■10	FC-0STUL	0ST
3.5	4.5	15	10	20	–	1	SF15B3A-■01	FC-0STUL	0ST
3	2.5	12	6	20	1	–	SF12B1G-■10	FC-0/GUL	0
3	2.5	12	6	20	–	1	SF12B1G-■01	FC-0/GUL	0
3.5	4.5	15	10	20	1	–	SF15B1A-■10	FC-0S/GUL	0S
3.5	4.5	15	10	20	–	1	SF15B1A-■01	FC-0S/GUL	0S
3	2.5	12	6	20	1	–	SF12B3G-■10	FC-0T/GUL	0T
3	2.5	12	6	20	–	1	SF12B3G-■01	FC-0T/GUL	0T
3.5	4.5	15	10	20	1	–	SF15B3G-■10	FC-0ST/GUL	0S
3.5	4.5	15	10	20	–	1	SF15B3G-■01	FC-0ST/GUL	0S
1.5	–	8	–	8	1	–	SF08BBG-■10	FC-0A/G	0A
1.5	–	8	–	8	–	1	SF08BBG-■01	FC-0A/G	0A

Notes: *1 Auxiliary contact arrangement 2NO or 2NC is available.
*2 Thermal current (A)

SF SERIES

ORDERING CODE SYSTEM

● Contactor

$\frac{S}{\textcircled{1}} \frac{F}{\textcircled{2}} \frac{1}{\textcircled{3}} \frac{2}{\textcircled{4}} B \frac{1}{\textcircled{5}} \frac{A}{\textcircled{6}} \text{---} \frac{E}{\textcircled{8}} \frac{2}{\textcircled{9}} \frac{2}{\textcircled{10}}$

① PRODUCT CATEGORY

Description	Code
Contactor	S

② SERIES CATEGORY

Description	Code
F series	F

③④ FRAME SIZE

Frame size	Code	
	③	④
0, 0T	1	2
0A	0	8
0S, 0ST	1	5
1	2	0
1S	2	6

⑤ VERSION

Description	Code
Non-reversing, open Contactor	
Standard	1
With tab terminal	T
Starter	
Standard	A

⑥ COIL SPECIFICATION

Description	Code
AC operating coil	A
DC operating coil	G

⑧ COIL VOLTAGE

● AC coil

Operating coil voltage		Code
50Hz	60Hz	
24V	24 — 26V	E
48V	48 — 52V	F
100V	100 — 110V	1
100 — 100V	110 — 120V	H
110 — 120V	120 — 130V	K
200V	200 — 220V	2
200 — 220V	220 — 240V	M
220 — 260V	240 — 260V	P
346 — 380V	380 — 420V	S
380 — 400V	400 — 440V	4
415 — 440V	440 — 480V	T

● DC coil

Operating coil voltage	Code
24V DC	E
48V DC	F
60V DC	G
100V DC	1
110V DC	H
200V DC	2
220V DC	M

⑨⑩ AUXILIARY CONTACT

Frame size 0 to 4

Contact arrangement	Code	
	⑨	⑩
1NO	1	0
1NC	0	1
2NO	2	0
1NO + 1NC	1	1
2NC	0	2

SF SERIES

■ TYPES AND RATINGS (IEC60947-4-1)

Frame size	Rated thermal current (A)	Voltage (V AC)	Making & breaking capacity (A)	Rated operational current (A)	
				Inductive	Resistive
0, 0A, 0T 0S	8	110	40	4	8
		220	40	4	8
		440	20	2	8
1, 1S	10	110	100	10	10
		220	60	6	10
		440	60	6	10

■ PERFORMANCE DATA

Frame size	Making capacity (A)	Breaking capacity (A)	Operating cycles per hour	Life expectancy (operations)	
				Electrical	Mechanical
0 to 1S	10 X I _e	10 X I _e	600	250,000	1 million

I_e: Rated operational current

■ DIMENSIONS, mm

Frame 0, 0S

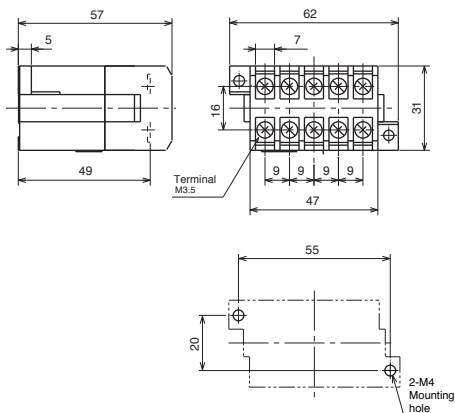

Mass: 160g

Frame 0T, 0ST

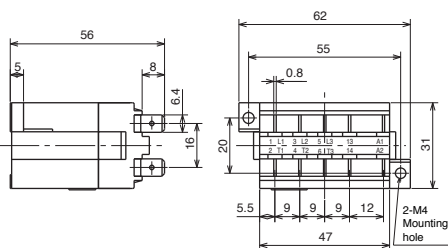

Mass: 160g

■ COIL RATINGS

Frame size	Power consumption (VA)		Voltage and frequency *	Wiring	Operating voltage range
	Inrush	Sealed			
0, 0A, 0T, 0S 1, 1S	23	6	200V 50Hz		0.75 to 1.1 times rated coil voltage
	75	11			

Notes: * Other voltages between 24V and 440V AC are available. DC operated type FC-0/G and FC-0T/G are also available. Coil voltage: 24, 48, 60, 100, 120, 200, 210 and 220V DC

Frame 0A

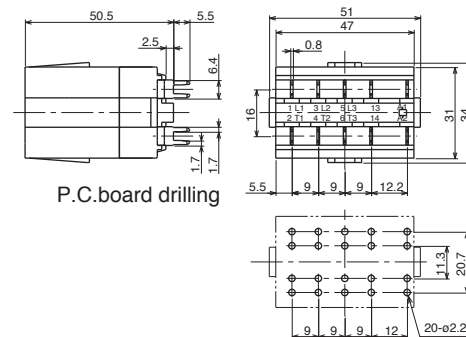

Mass: 140g

Frame 1, 1S

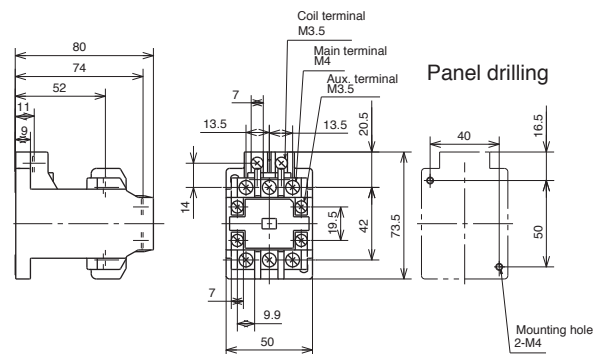

Mass: 160g

1. Contactor

Latest Contactor	US part number	4NC0A0	4NC0F0	4NC0G0	4NC0Q0	4NC0R0	4NC0H0	4NC0H0+SZ-A11	3NC0T0	3NC1Q0	3NC2F0
	Japanese part number	SC-03	SC-0	SC-05	SC-4-0	SC-4-1	SC-5-1	SC-5-1+SZ-A11	SC-N1	SC-N2	SC-N2S
	Dimensions (mm)	W43*H80*D80	W43*H80*D80	W53*H80*D80	W53*H80*D81	W53*H80*D81	W64*H80*D81	W64*H80*D109	W74*H87*D96	W74*H87*D96	W88*H110*D111
	Installation hole pitch (mm)	W30*H48	W30*H48	W34*H52 (48)	W34*H52 (48)	W34*H52 (48)	W35*H60	W35*H60	W45 (50)*H75	W45 (50)*H75	W60 (55)*H90
		W34*H52 (48)	W34*H52 (48)	W35*H60	W35*H60	W35*H60	W50*H60	W50*H60	W65 (60)*H70	W65 (60)*H70	W70*H75
W35*H60	W35*H60	W54*H60 (56)	W54*H60 (56)								
Adapter plate for 2NC installation holes	-	-	-	-	-	-	-	-	Not required	Not required	Not required
2NC Contactor	US part number	-	-	-	-	-	-	-	2NC0T0	3NC1Q0	2NC2F0
	Japanese part number	-	-	-	-	-	-	-	SC-1N	SC-2N	SC-2SN
	Dimensions (mm)	-	-	-	-	-	-	-	W74*H87*D103	W74*H87*D103	W88*H110*D118
	Installation hole pitch (mm)	-	-	-	-	-	-	-	W65 (60)*H70	W65 (60)*H70	W70*H75
1RC, 1SC (SRC, SC) Contactor	US part number	-	1RC0A0	1RC0B0	-	-	1RC0F0	-	-	1RC1F0	-
	Japanese part number	SRC3631-02	SRCa3631-0	SRCa3631-05	-	-	SRC3631-5-1	SRC3631-5-1N	SRC3631-5-2	SRCa3631-2	SC-2S
	Dimensions (mm)	W43*H57*D62	W45*H71*D75	W53*H71*D75	-	-	W68*H71*D79	W68*H71*D91.5	W78*H90*D98	W88*H100*D105	W88*H120*D122.5
	Installation hole pitch (mm)	W30*H48	W34*H52 (48)	W34*H52 (48)	-	-	W54*H59 (56)	W54*H59 (56)	W65 (60)*H70	W71 (68)*H65	W70*H75
Old SRC, SC Contactor	US part number	-	-	-	-	-	-	-	-	-	-
	Japanese part number	-	-	-	-	-	-	-	-	-	SRC3631-2T
	Dimensions (mm)	-	-	-	-	-	-	-	-	-	W88*H145*D105
	Installation hole pitch (mm)	-	-	-	-	-	-	-	-	-	W71 (68)*H65

Latest Contactor	US part number	3NC2H0	3NC2T0	3NC3F0	3NC3H0	3NC4F0	3NC4Q0	3NC4H0	3NC5F0	3NC5H0
	Japanese part number	SC-N3	SC-N4	SC-N5	SC-N6	SC-N7	SC-N8	SC-N10	SC-N11	SC-N12
	Dimensions (mm)	W88*H110*D111	W88*H127*D117	W88*H127*D132	W100*H144*D138	W115*H156*D140	W138*H209*D174	W138*H209*D174	W148*H240*D195	W148*H240*D195
	Installation hole pitch (mm)	W60 (55)*H90	W70*H75	W70*H75	W90 (80)*H110	W90 (80)*H110	W45*H190	W45*H190	W60*H220	W60*H220
		W70*H75								
Adapter plate for 2NC installation holes	Not required	Not required	SZ-N5/AP	Not required	SZ-N7/AP	Not required	Not required	SZ-N11/AP	Not required	
2NC Contactor	US part number	2NC2H0	2NC2T0	2NC3F0	2NC3H0	2NC4F0	2NC4Q0	2NC4H0	2NC5F0	2NC5H0
	Japanese part number	SC-3N	SC-4N	SC-5N	SC-6N	SC-7N	SC-8N	SC-10N	SC-11N	SC-12N
	Dimensions (mm)	W88*H110*D118	W88*H125*D137.5	W100*H148*D151	W100*H148*D151	W120*H167*D167.5	W138*H210*D194	W138*H210*D194	W148*H230*D208.5	W163*H240*D230.5
	Installation hole pitch (mm)	W70*H75	W70*H75	W80*H110	W80*H110	W100*H130	W45*H190	W45*H190	W50*H210	W60*H220
1RC, 1SC (SRC, SC) Contactor	US part number	1SC2H0	-	1SC3F0	1SC4F0	-	-	1SC4H0	-	-
	Japanese part number	SC-3	SC-4	SC-4S	SC-6	-	-	SC-8	SC-10	SC-12
	Dimensions (mm)	W88*H120*D122.5	W100*H132*D136	W100*H148*D136	W120*H160*D152	-	-	W138*H210*D180	W148*H230*D194.5	W173*H240*D218.5
	Installation hole pitch (mm)	W70*H75	W80*H110	W80*H110	W100*H130	-	-	W45*H190	W50*H210	W60*H220
Old SRC, SC Contactor	US part number	-	-	-	-	-	-	-	-	-
	Japanese part number	SRC3631-3	SRC3631-4	SRC3631-4T	SRC3631-6	-	-	SRC3631-8	SRC3631-10	SRC3631-12
	Dimensions (mm)	W104*H117*D140	W160*H155*D109	W160*H166*D109	W195*H199*D130	-	-	W204*H223*D153	W212*H257*D168	W300*H283*D200
	Installation hole pitch (mm)	W90*H85	W57*H138	W57*H138	W70*H175	-	-	W70*H165	W80*H190	W115*H222

2. Motor Starter

Latest Motor Starter	US part number (Contactor + Overload)	4NW0A0 (4NCOA0 + 4NKO0A)	4NW0F0 (4NCOF0 + 4NKO0A)	4NW0G0 (4NCOG0 + 4NKO0A)	4NW0Q0 (4NCOQ0 + 4NKO0H)	4NW0R0 (4NCO00 + 4NKO0H)	4NW0H0 (4NCOH0 + 4NKO0H)	4NW0H0+SZ-A11 (4NCOH0 + 4NKO0H)	3NW0T0 (3NCO00 + 3NKT0)	3NW1Q0 (3NCO100 + 3NKT1Q)	3NW2F0 (3NCO200 + 3NKT2H)	
	Japanese part number (Contactor + Overload)	SW-03 (SC-03 + TK-0N)	SW-0 (SC-0 + TK-0N)	SW-05 (SC-05 + TK-0N)	SW-4-0 (SC-4-0 + TK-5-1N)	SW-4-1 (SC-4-1 + TK-5-1N)	SW-5-1 (SC-5-1 + TK-5-1N)	SW-5-1+SZ-A11 (SC-5-1 + TK-5-1N)	SW-N1 (SC-N1 + TK-N2)	SW-N2 (SC-N2 + TK-N2)	SW-N2S (SC-N2S + TK-N3)	
	Dimensions (mm)	W44*H120*D80	W44*H120*D80	W53*H120*D80	W53*H126*D81	W53*H126*D81	W64*H126*D81	W64*H126*D109	W74*H146*D96	W74*H146*D96	W88*H177*D111	
	Installation hole pitch (mm)	W30*H48 W34*H52 (48) W35*H60	W30*H48 W34*H52 (48) W35*H60	W34*H52 (48) W35*H60	W34*H52 (48)	W34*H52 (48)	W34*H52 (48)	W50*H60 W54*H60 (56)	W35*H60 W50*H60 W54*H60 (56)	W65 (60)*H70	W65 (60)*H70	W70*H75 W60 (55)*H90
	Adapter plate for 2NW installation holes	-	-	-	-	-	-	-	-	Not required	Not required	SZ-N2SW/AP
2NW Motor Starter	US part number (Contactor + Overload)	-	-	-	-	-	-	-	2NW0T0 (2NCO00 + 2NKT0)	2NW1Q0 (2NCO100 + 2NKT1Q)	2NW2F0 (2NCO200 + 2NKT2H)	
	Japanese part number (Contactor + Overload)	-	-	-	-	-	-	-	SW-1N (SC-1N + TK-2N)	SW-2N (SC-2N + TK-2N)	SW-2SN (SC-2SN + TK-3N)	
	Dimensions (mm)	-	-	-	-	-	-	-	W74*H141*D103	W74*H141*D103	W88*H215*D123	
	Installation hole pitch (mm)	-	-	-	-	-	-	-	W65 (60)*H70	W65 (60)*H70	W70*H200	
1RW, 1SW (SRC, SW) Motor Starter	US part number (Contactor + Overload)	-	1RW0A0 (1RC0A0 + 1TR0A)	1RW0B0 (1RC0B0 + 1TR0A or 1TK0F)	-	-	-	1RW0F0 (1RC0F0 + 1TK0F)	-	1RW1F0 (1RC1F0 + 1TK1F)	-	
	Japanese part number (Contactor + Overload)	SRCa3931-02 (SRC3631-02 + TR-0)	SRCb3931-0 (SRCa3631-0 + TR-0)	SRCa3931-05 (SRCa3631-05 + TR-0 or TR-1S)	-	-	-	SRCa3931-5-1 (SRC3631-5-1 + RCa3737-1C)	SRC3931-5-1N (SRC3631-5-1N + RCa3737-1C)	SRCa3931-5-2 (SRC3631-5-2 + TR-2)	SRCa3931-2 (SRCa3631-2 + TR-2)	SW-2S (SC-2S + TR-3)
	Dimensions (mm)	W50*H93.5*D70	W51.5*H104.5*D79.5	W53*H104.5*D79.5 W68*H126*D94.5	-	-	-	W68*H99*D79 W68*H150*D94	W74*H99*D91.5	W78*H150*D114	W92*H172*D110	W88*H215*D127.5
	Installation hole pitch (mm)	W30*H48	W34*H52 (48)	W34*H52 (48) W50*H115	-	-	-	W54*H59 (56) W55*H140	W54*H59 (56)	W60*H140	W71 (68)*H65	W70*H200
Old SRC Motor Starter	US part number (Contactor + Overload)	-	-	-	-	-	-	-	-	-	-	
	Japanese part number (Contactor + Overload)	SRC3931-02 (SRC3631-02 + TH-0)	SRCa3931-0 (SRCa3631-0 + TH0)	SRC3931-05 (SRC3631-05 + TH-0)	-	-	-	SRC3931-5-1 (SRC3631-5-1 + RCa3737-1H)	SRCa3931-5-1F (SRC3631-5-1F + RCa3737-1C)	SRC3931-5-2 (SRC3631-5-2 + ACH-2HM)	SRC3931-2 (SRC3631-2 + RC3737-4)	SRC3931-2T (SRC3631-2T + RC3737-4)
	Dimensions (mm)	W48.5*H84*D65	W50.5*H97.5*D75.5	W53*H97.5*D75	-	-	-	W68*H99*D79	W74*H99*D104	W76*H150*D105	W92*H172*D110	W92*H189*D110
	Installation hole pitch (mm)	W30*H48	W34*H52 (48)	W34*H52 (48)	-	-	-	W54*H59 (56)	W54*H59 (56)	W60*H140	W67*H160	W67*H160

Latest Motor Starter	US part number (Contactor + Overload)	3NW2H0 (3NC2H0 + 3NK2H)	3NW2T0 (3NC2T0 + 3NK3F)	3NW3F0 (3NC3F0 + 3NK3F)	3NW3H0 (3NC3H0 + 3NK3H)	3NW4F0 (3NC4F0 + 3NK4F)	3NW4Q0 (3NC4Q0 + 3NK4Q)	3NW4H0 (3NC4H0 + 3NK4H)	3NW5F0 (3NC5F0 + 3NK5H)	3NW5H0 (3NC5H0 + 3NK5H)
	Japanese part number (Contactor + Overload)	SW-N3 (SC-N3 + TK-N3)	SW-N4 (SC-N4 + TK-N5)	SW-N5 (SC-N5 + TK-N5)	SW-N6 (SC-N6 + TK-N6)	SW-N7 (SC-N7 + TK-N7)	SW-N8 (SC-N8 + TK-N8)	SW-N10 (SC-N10 + TK-N10)	SW-N11 (SC-N11 + TK-N12)	SW-N12 (SC-N12 + TK-N12)
	Dimensions (mm)	W88*H177*D111	W88*H189*D117	W88*H189*D132	W100*H225*D138	W115*H237*D140	W138*H305*D174	W138*H287*D174	W148*H360*D195	W148*H360*D195
	Installation hole pitch (mm)	W60 (55)*H90 W70*H75	W70*H75	W70*H75	W90 (80)*H110	W90 (80)*H110	W45*H270	W45*H270	W60*(H220+H330)	W60*(H220+H330)
	Adapter plate for 2NW installation holes	SZ-N2SW/AP	SZ-N4W/AP	SZ-N5W/AP	SZ-N5W/AP	SZ-N7W/AP	SZ-N8W/AP	SZ-N8W/AP	SZ-N11W/AP	SZ-N12W/AP
2NW Motor Starter	US part number (Contactor + Overload)	2NW2H0 (2NC2H0 + 2NK2H)	2NW2T0 (2NC2T0 + 2NK2T)	2NW3F0 (2NC3F0 + 2NK4F)	2NW3H0 (2NC3H0 + 2NK4F)	2NW4F0 (2NC4F0 + 2NK4F)	2NW4Q0 (2NC4Q0 + 2NK4Q)	2NW4H0 (2NC4H0 + 2NK4H)	2NW5F0 (2NC5F0 + 2NK5F)	2NW5H0 (2NC5H0 + 2NK5H)
	Japanese part number (Contactor + Overload)	SW-3N (SC-3N + TK-3N)	SW-4N (SC-4N + TK-4N)	SW-5N (SC-5N + TK-6N)	SW-6N (SC-6N + TK-6N)	SW-7N (SC-7N + TK-6N)	SW-8N (SC-8N + TK-8N)	SW-10N (SC-10N + TK-10N)	SW-11N (SC-11N + TK-11N)	SW-12N (SC-12N + TK-12N)
	Dimensions (mm)	W88*H215*D123	W88*H240*D142.5	W119*H265*D156	W119*H265*D156	W120*H218*D174.5	W138*H317*D194	W148*H320*D194	W173*H370*D208.5	W173*H370*D230.5
	Installation hole pitch (mm)	W70*H200	W70*H225	W80*H250	W80*H250	W100*H275	W45*H300	W45*(H190+H300)	W50*(H210+H350)	W60*(H220+H350)
1RW, 1SW (SRC, SW) Motor Starter	US part number (Contactor + Overload)	1SW2H0 (1SC2H0 + 1TK2H)	-	1SW3F0 (1SC3F0 + 1TK4F)	1SW4F0 (1SC4F0 + 1TK4F)	-	-	1SW4H0 (1SC4H0 + 1TK4H)	-	-
	Japanese part number (Contactor + Overload)	SW-3 (SC-3 + TR-3)	SW-4 (SC-4 + TR-4)	SW-4S (SC-4S + TR-6)	SW-6 (SC-6 + TR-6)	-	-	SW-8 (SC-8 + TR-8)	SW-10 (SC-10 + TR-10)	SW-12 (SC-12 + TR-12)
	Dimensions (mm)	W88*H215*D127.5	W100*H265*D141	W119*H266*D141	W120*H265*D141	-	-	W138*H317*D180	W148*H320*D194.5	W173*H370*D218.5
	Installation hole pitch (mm)	W70*H200	W80*H250	W80*H250	W100*H250	-	-	W45*H300	W50*(H210+H300)	W60*(H220+H350)
Old SRC Motor Starter	US part number (Contactor + Overload)	-	-	-	-	-	-	-	-	-
	Japanese part number (Contactor + Overload)	SRC3931-3 (SRC3631-3 + RC3737-4)	SRC3931-4 (SRC3631-4 + RC3737-4)	SRC3931-4T (SRC3631-4T + RC3737-10T)	SRC3931-6 (SRC3631-6 + RC3737-10)	-	-	SRC3931-8 (SRC3631-8 + RC3737-10)	SRC3931-10 (SRC3631-10 + RCa3737-20N)	SRC3931-12 (SRC3631-12 + RC3737-30N)
	Dimensions (mm)	W104*H192*D145	W160*H214*D109	W168.5*H292*D109	W204.5*H325*D130	-	-	W215.5*H345*D153	W221*H399*D168	W300*H411*D200
	Installation hole pitch (mm)	W90*H177	W57*H138	(W57, W22.5)* (H138+H270)	(W70, W52.5)* (H175+H305)	-	-	(W70, W51.5)* (H165+H292)	(W80, W59)* (H190+H355)	(W115, W60, W70)* (H222+H361)

3. Industrial Relay

Latest SH Industrial Relay	US part number	4SH4		4SH5		4SH4 + SZ-A11		4SH4 + SZ-A20 or SZ-A02 or SZ-A11		4SH8		4SH5 + SZ-A40 or SZ-A22					
	Japanese part number	SH-4 (4pole)		SH-5		SH-4 + SZ-A11		SH-4 + SZ-A20 or SZ-A02 or SZ-A11		SH-4 (8pole)		SH-4 (8pole) + SZ-A40 or SZ-A22					
	Number of contacts	4		5		6		6		8		9					
	Contact arrangement	4NO, 3NO1NC, 2NO2NC		5NO, 4NO1NC, 3NO2NC, 2NO3NC, 1NO4NC, 5NC		3NO3NC		6NO, 4NO2NC, 5NO1NC, 3NO3NC		8NO, 7NO1NC, 6NO2NC, 5NO3NC, 4NO4NC		9NO, 8NO1NC, 7NO2NC, 6NO3NC, 5NO4NC, 4NO5NC					
	Dimensions (mm)	W43*H80*D80		W53*H80*D80		W43*H80*D108		W43*H80*D108		W43*H80*D108		W53*H80*D108					
	Installation hole pitch (mm)	W30*H48		- W34*H52 (48)		W30*H48		W30*H48		W30*H48		W34*H52 (48)					
		W34*H52 (48)		W34*H52 (48)		W34*H52 (48)		W34*H52 (48)		W34*H52 (48)		W35*H60					
W35*H60		W35*H60		W35*H60		W35*H60		W35*H60									
Old RH Industrial Relay	US part number	1RH4		-	1RH5		-	-	-	1RH8		-					
	Japanese part number	SRCa50-3/X		SRC50-05/X		SRC50-4/X		SRC50-2F/X		SRC50-2U/X		SRC50-3FS/X		SRCa50-3F/X		SRC50-4F/X	
	Number of contacts	4		5		5		6		6		5		8		10	
	Contact arrangement	4NO, 3NO1NC, 2NO2NC		5NO, 4NO1NC, 3NO2NC		5NO, 4NO1NC, 3NO2NC, 2NO3NC, 1NO4NC, 5NC		3NO3NC		6NO, 4NO2NC, 5NO1NC, 3NO3NC		4NO4NC		8NO, 6NO2NC, 5NO3NC, 4NO4NC		5NO5NC	
	Dimensions (mm)	W43*H71*D81		W53*H71*D81		W68*H71*D86.5		W37.5*H67.5*D90		W37.5*H67.5*D94.5		W44*H64*D92.5		W43*H71*D112		W68*H71*D111.5	
	Installation hole pitch (mm)	W34*H52 (48)		W34*H52 (48)		W54*H59 (56)		W27*H54 (52)		W27*H54 (52)		W34*H52 (48)		W34*H52 (48)		W54*H59 (56)	

WARRANTY

■ TERMS AND CONDITIONS OF SALE

Prices

All prices are subject to change without notice. In the event of a price change, the effective date of the change will be the date on the new price or discount schedule sheet.

All quotations made or orders accepted after the effective date will be based on the new prices.

Quotations

Written quotations are valid for 30 days from its date unless otherwise stated in the quotation. Verbal quotations expire the same day they are made.

Taxes

The price does not include any taxes. Buyer shall be responsible for the payment of all applicable taxes.

Terms of payment

Terms of payment will be listed on the quotations.

Minimum orders

Terms of minimum order will be shown on quotations, or if orders amounting to less than the latest minimum order amount, handling fee will be applied.

Delivery

Delivery of products shall be FOB point of origin in the U.S. Seller shall determine the point of origin of shipment. All shipping and other charges shall be paid by Buyer.

Packing

Prices include standard domestic packing. Additional special packing costs required for export or by Buyer's request will be charged to Buyer.

Weight and Dimensions

The weight and dimensions of products described in this catalog are the best information available at the time of going to press. As Seller follows a policy of continuous product improvement, design changes may make this information obsolete. Information in this catalog is subject to change without notice.

Inspection and acceptance of products

Buyer is responsible for inspecting and evaluating received products for final acceptance. All claims of shortage or damage must be made within thirty (30) days of receipt of products.

Return / Cancellation

No product shall be returned or cancelled unless return/order cancel authorization has been secured from Seller. All returns/cancellations must comply with Seller's then current Return / Cancellation policy.

Risk of Loss

Risk of loss or damage to the product shall pass to Buyer at the FOB point.

Catalog Disclaimer

The information contained in this catalog does not constitute an express or implied warranty of quality, any warranty of merchantability or fitness for a particular purpose is hereby disclaimed. Since the Buyer's product information, specific use application, and conditions of use are all outside of Seller's control, it shall be the responsibility of the Buyer to determine the suitability of any of the products mentioned for the Buyer's application.

ONE YEAR LIMITED WARRANTY

The products identified in this catalog shall be sold pursuant to the terms and conditions identified in the Conditions of Sale issued by Fuji Electric with each order confirmation. Except to the extent otherwise provided for in the Conditions of Sale issued by Fuji Electric, Fuji Electric warrants that the Fuji Electric products identified in this catalog shall be free from significant defects in materials and workmanship provided the products have not been: (1) repaired or altered by others than Fuji Electric; (2) subjected to negligence, accident, misuse, or damage by circumstances beyond Fuji Electric's control; (3) improperly operated, maintained or stored; or (4) used in other than normal use or service. This warranty shall apply only to defects appearing within one (1) year from the date of shipment by Fuji Electric, and in such case, only if such defects are reported to Fuji Electric within thirty (30) days of discovery by purchaser.

Such notice should be submitted in writing to Fuji Electric Corp. of America. The sole and exclusive remedy with respect to the above warranty whether such claim is based on warranty, contract, negligence, strict liability or any other

theory, is limited to the repair or replacement of such product or, at Fuji Electric's option, reimbursement by Fuji Electric of the purchase price paid to Fuji Electric for the particular product. **FUJI ELECTRIC DOES NOT MAKE ANY OTHER REPRESENTATIONS OR WARRANTIES, WHETHER ORAL OR IN WRITING, EXPRESSED OR IMPLIED, INCLUDING BUT NOT LIMITED TO ANY WARRANTY REGARDING MERCHANTABILITY OR FITNESS FOR A PARTICULAR PURPOSE.**

Except as provided in the Conditions of Sale, no agent or representative of Fuji Electric is authorized to modify the terms of this Warranty in writing or orally.

In no event shall Fuji Electric be liable for special, indirect or consequential damages, including but not limited to, loss of use of the product, other equipment, plant, power system, loss of profits or revenues, cost of capital, or claims against the purchaser or user by its customers resulting from the use of information, recommendations and descriptions contained herein. Purchaser agrees to pass on to its customers and users, in writing at the time inquiries and orders are received by buyer, Fuji Electric's warranty as set forth above.

Your local authorized stocking distributor is:

Printed on recycled paper

**Fuji Electric FA Components
& Systems Co., Ltd.**

Mitsui Sumitomo Bank Ningyo-cho Bldg., 5-7
Nihonbashi Odemma-cho, Chuo-ku, Tokyo 103-0011, Japan
Phone : +81-3-5847-8042
Fax : +81-3-5847-8172
Website : www.fujielectric.co.jp/fcs

**Fuji Electric Corp.
of America**

47520 Westinghouse Drive
Fremont, CA 94539
Phone: 510-440-1060
Fax: 510-440-1063
Website : www.americas.fujielectric.com